

Amtgard

Rules of Play 7th edition

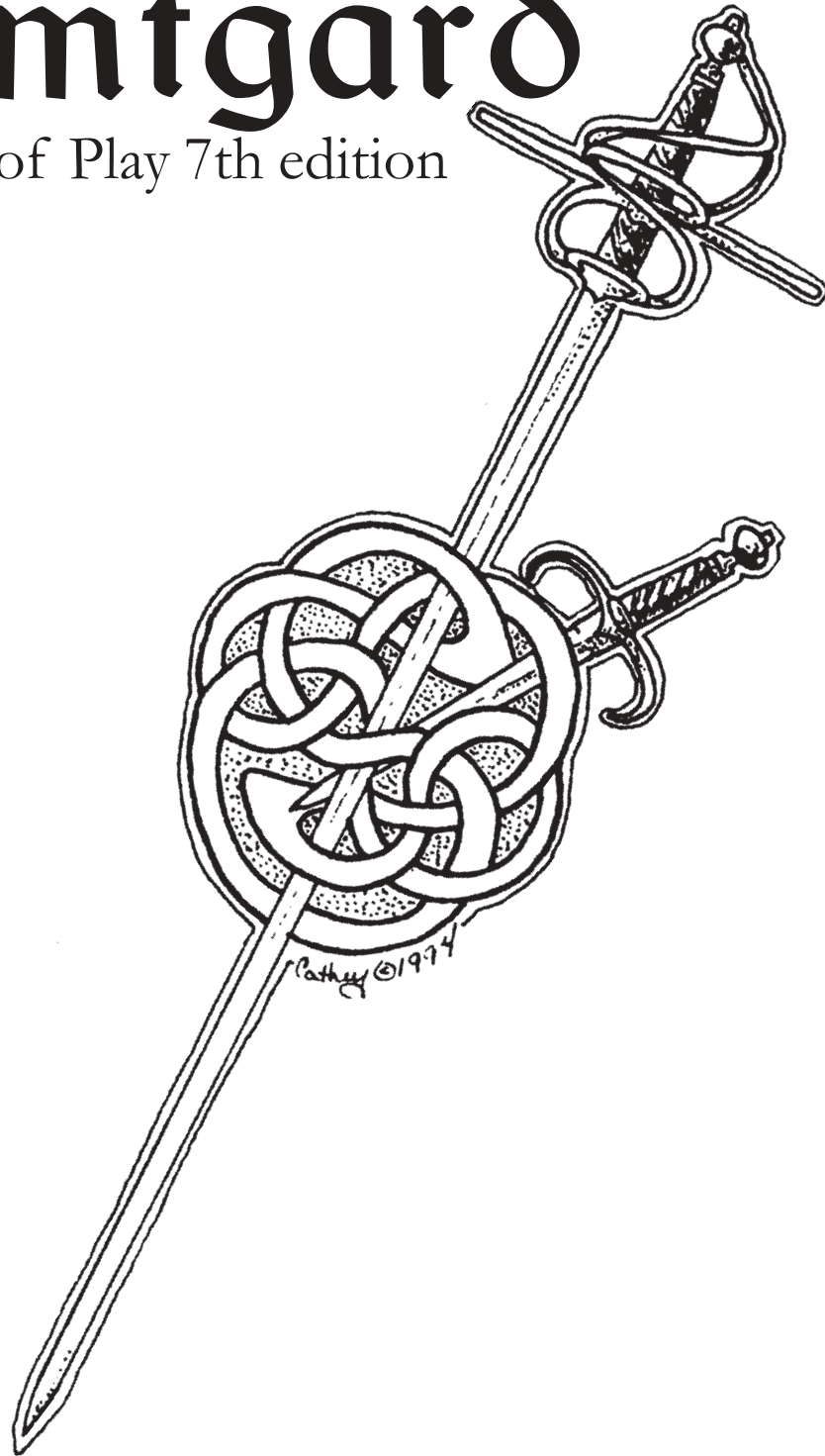

Contents

1	Forward
2	Introduction
3	Persona Guidelines
4	Combat, Weapons, and Equipment
5	Equipment
6	Weapons
	Weapon Types
7	Weapon Effects
	Archery
	Siege Weapons
8	Shields
	Equipment Construction Notes
	Sword Construction Tutorial
9	Shield Construction
	Arrow Construction
	Projectiles
10	Armor Construction
11	Armor Definitions
12	Battle Games
14	Fighting Classes and Abilities
15	Standard Classes
	Anti-Paladin
	Archer
16	Assassin
	Barbarian
17	Bard
	Druid
18	Healer
	Monk
	Monster
18	Paladin
	Peasant
	Raider
19	Scout
	Warrior
20	Wizard
	Abilities and Traits defined
26	Amtgard Magic
	The Rules of Magic
28	Magic Clarifications
	Magic Relics
29	The Schools of Magic
32	Magic per Class and Level
	Bard Magic
33	Druid Magic
34	Healer Magic
35	Wizard Magic
36	Magic Descriptions
53	Monsters
54	Monster Definitions
55	Monster Descriptions
	Brownie
56	Centaur
	Dryad
57	Giant, Hill
	Goblin
58	Lizardman
	Mummy
59	Pegasus
	Siren
60	Troll, Regenerating
61	Unicorn
	Zombie
62	Monster Abilities and Traits
63	Glossary
66	Credits



Amtgard

The Rules of Play v 7

Foreword

It's been a decade, more or less, since the last release of the rules of play. This release is representative of many lessons learned and experience gained over that ten-year period. In that time, Amtgard has become geared towards a faster, more engaging and interesting system of play, and was in dire need of rules to match. The original goal was to clear up gray areas and loopholes in the rules, and those clarifications brought with them many significant changes, as well as further attempts to balance the game.

It was not an easy task - and to be certain, some things were missed; still, we think this represents the best that all the kingdoms could contribute and reflects the general consensus of how things should work. This is the first rulebook that is a truly inter-kingdom effort, and it shows. It was a long, hard road to produce the work you are about to read and in the end, it came down to the blood, sweat, and tears of a very few people. Given that this is probably the only set of words all Amtgardians will read, we feel we should take this chance to remind everybody what we believe this game really is.

The game isn't about fighting, or arts and sciences, or role-playing (though of course those all exist and flourish within the game). The game is about the people. It is the people, all of the people, who have made this game work for over 20 years. It is the people, past and present, which make Amtgard the great organization it is today. Every day you step out into the park, try to remember it is the people who surround you that make the game. No matter what our differences may be, at our heart we all share a common bond, and a common Dream.

We hope you enjoy the new rulebook and find it an improvement over the previous one. Happy gaming!

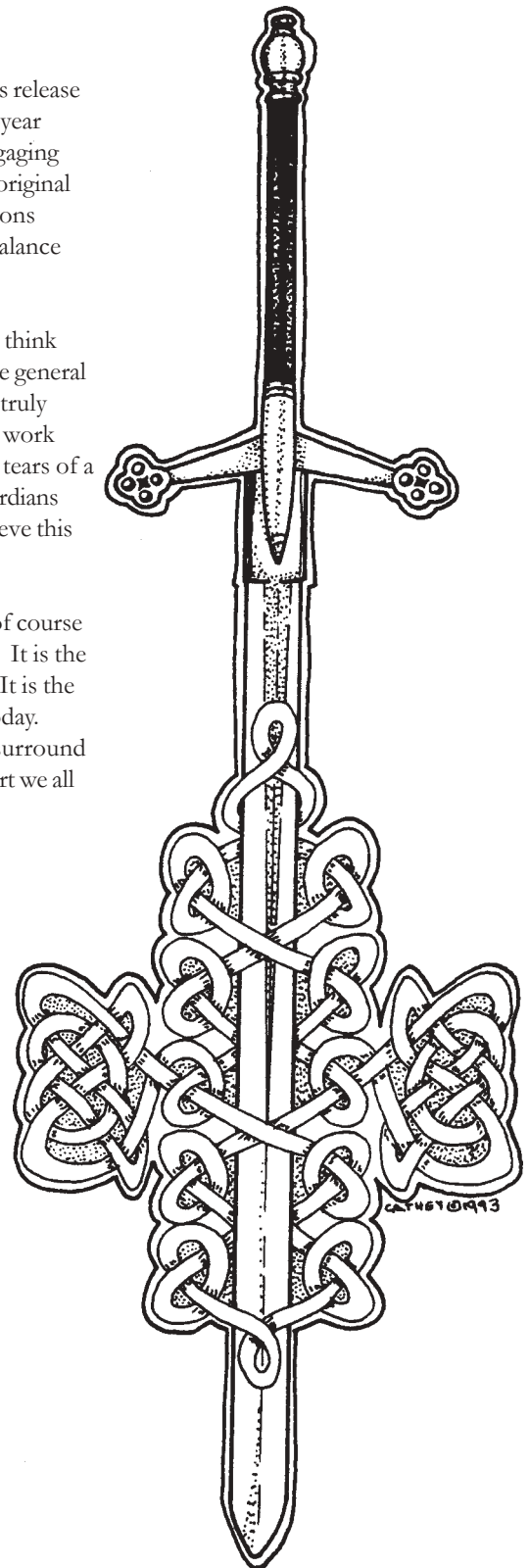

Getting Started

Introduction



Note: ‘His/he/him’ is used exclusively in this publication as convention and for simplicity only. All aspects of Amtgard are open to both males and females.

Amtgard is a not-for-profit, free, non-sectarian group dedicated to the recreation of medieval and fantasy genres. Amtgard has a vast array of new experiences to offer the interested adventurer, from making clothing appropriate to a certain time period, to wielding a foam-padded replica of an ancient weapon on the field of battle. The recreation of medieval and fantasy combat is the core of Amtgard and the main concern of this tome. The rules set forth herein are as detailed and complete as possible, but not all situations can be covered. Common sense and fair play should be used to resolve any problems. Anyone may join Amtgard by:

- 1) Obtaining a copy of this rulebook and reading it.
- 2) Developing a persona and a persona history.
- 3) Making a costume for yourself that is fitting to your persona.
- 4) Filling out a membership form and waiver and turning them in to the Prime Minister. Minors must have their waivers signed by their parents or legal guardians. Minors under the age of 14 may not participate in combat without special permission from the Monarch.

In addition to these requirements, players may opt to become ‘dues paid.’ Dues paid members have no advantage over other members except that they may vote in the bi-monthly Althing meetings, which are used to make decisions for the group that are beyond the scope of the monarch alone, such as changing the corpora. Dues paid members are also the only ones who may vote in elections. Dues are six dollars every six months and all dues collected are used to pay for rulebooks, newsletters, loaner gear, and other group expenses.

Other Amtgard publications of importance include:

- 1) **Corpora of Amtgard bylaws** – group criteria, Amtgard governmental structure, awards and honors, etc. Important for all groups, essential for medium/large groups. This document also explains the criteria for becoming a knight, warlord, etc.
- 2) **The Amtgard Contract** – Legal agreement that all groups must sign with the Board of Directors of Amtgard, Kingdom of the Burning Lands (doing business as Amtgard, Inc.) It ensures that groups will abide by the Amtgard rules and bylaws.
- 3) **Other Publications of note** – While not mandatory, these publications are very useful and include Amtgard supplements, such as garb and weapon making, an FAQ list, and the Dor Un Avathar (a monster handbook). These and other publications may be found at www.Amtgard.com.

The rulebook takes precedence over all supplements, manuals and other rules editions or play testing supplements. From time to time there may be official manuals, supplements, or expansions that enhance or compliment the core rule set. While these documents may expand game play options they are still restrained by the core rules written herein and may not contradict them. In the event of a contradiction between the rulebook and any other supplemental materials, this core rulebook always takes precedence.

Process for updating these rules:

Changes to this document may only be made by a 75% vote of the Circle of Monarchs. All votes must be sent to a representative designated by the circle via registered mail. Circle of Monarchs votes are generally collected during the months of June and July.

Persona Guidelines

Real history: a persona should be based on people who could have lived before 1650 ad. The name, weapons, clothing, etc. Are encouraged to be historically correct. Do not impersonate a famous historical figure.

Fantasy: the persona should be based on a book, movie, historical mythology, or a unique creation of your own. Again, do not impersonate a character from the medium you choose.

Remember: every persona must be either of an ancient, medieval, or swords and sorcery related background.

Heraldry

Create a device or insignia to display on your flags, banners, and coat of arms. The device should be unique or at least in keeping with your persona or company. You may register the device with the guildmaster of heraldry and the prime minister.

Companies

People may wish to band together as a fighting group. This group is called a company. The company should choose a name, captain, second in command and device. A person may be in no more than one company.

Households

People who wish to form a non-fighting group within the club can create a household. The household should choose a name, a master and mistress of the house and a device. A person may be in any number of households.

Events

There are many types of games and events held regularly. These include:

- 1) Tournaments- competitions between individuals or groups for awards, honor, or challenges.
 - 2) Battles- involves two or more armies attacking each other for various reasons.
- Special events- quests, feasts, demos, trips, revels, fairs, workshops, and other 'games.'



Combat, Weapons, and Equipment

Combat Rules



Damage and wounds to you:

Head and Neck – Out of bounds. Will not count as a hit and is illegal. Deliberately parrying with your head or neck is prohibited.

Arm – The first hit to the arm will result in the loss of use of that limb. A struck arm must be kept behind your back. A second hit to the wounded arm will result in death. Hand shots count as a hit to the arm unless you are holding a melee weapon in that hand, in which case it counts as hitting the weapon. Wrists are considered part of the arm, not the hand.

Leg – A hit to a leg results in the loss of use of that leg. You must drop to one knee as soon as is feasible and place the dead knee on the ground. Any following hits to that leg will have no effect (the only exceptions are magical balls and some siege weapons). Crawling, dragging one's self and being carried are the only ways to move about with a wounded leg. You may make a short spring at an opponent with your good leg; however, hopping on your good leg is not allowed.

Torso – (Includes a person's shoulders, groin, chest, back, and buttocks) instant death.

Feet – Do not count as a hit if they are on the ground when struck (exception: magical balls); otherwise they count as a hit to that leg.

Combat Notes:

- 1) Any two shots to the limbs (except two shots to the same leg) results in death. Example: You are struck in the arm. The arm must then be placed behind your back and is useless. You are then struck again in any limb, including the one behind your back, and die.
- 2) A single shot to a hit location, regardless of weapon type or point value, only counts as one blow to the hit location and any 'extra' damage never carries through to another hit location. Example: Being struck in the arm with a Red weapon only wounds the arm. The extra damage is ignored.
- 3) Shots that only strike garb or equipment do not count as a hit unless said items blocked a blow that would have struck a combatant (i.e. - garb, equipment, sheathed weapons, etc. Are not shields and do not count as armor).
- 4) Blows that nick or lightly glance off of a target do not count as hits. Any shot that stops or any shot that hits then deflects at an angle is considered a hit. See also '**A Valid Shot**' below.
- 5) Projectiles and arrows that nick or lightly glance still count as hits.
- 6) The chain portion of flails are not legal striking edges and do not count as hits. The same applies to all weapon hafts, hilts, hand guards, and courtesy-padded shafts.
- 7) Deflections that then strike true on a target are hits, with the exception of shots that deflect off the head or neck. Deflections from illegal targets do not count. Projectiles, even on deflections, can only deal damage to a single target i.e. A throwing dagger hitting an arm and then deflecting into the chest only wounds the arm, it does not affect the chest.
- 8) If a person is wounded in an arm throwing a shot, or killed, shots they threw into motion before being struck still count as a hit, if they land within a half second of being struck. In the case of a two-handed weapon, the wielder must remove his wounded hand from the weapon within a half second for the shot to count. This should be a clear case of finishing an already thrown shot, meaning that it requires no change of direction and the last action required to finish the shot has already been started prior to being struck. If you have any questions, ask your kingdom/group level Guildmaster of Reeves. A reeve's call is always final in determining if a shot is in time or late.
- 9) Shots that knock aside a parry and then strike the target are hits.
- 10) Illegal shots stop the shot and pause the action if necessary for your opponent to recover (i.e. If you hit your opponent in the face, stop combat until he indicates he is unhurt).
- 11) Bounces never count from projectiles, magic balls, and arrows.

- 12) A player who consistently breaks game rules, cheats, causes mundane problems with authorities or safety can be barred from the local group or kingdom by joint agreement of the Monarch and either the Prime Minister or the Guildmaster of Reeves of that group.
- 13) Players may not wield more than one weapon in a single hand.
- 14) Grappling with an opponent; shield bashing; rough, dangerous, or offensive physical contact is strictly prohibited and can result in being banned from play indefinitely.
- 15) If you have to think about whether or not a shot was 'good enough' to count, it probably was. Always endeavor to have unquestionable honor in the area of calling your own shots. Your peers will respect you and return the favor.
- 16) Do not call another person's shots unless you are a reeve. It is rude and considered in poor form. If you consistently have problems with a player not taking their shots, inform a reeve who will deal with them appropriately.

Combat with armor:

Armor is rated on its ability to stop blows. The rating ranges from 1 to 7 points, though some monsters can have more. The same damage rules apply to armor. Each strike will remove one point of value from the armor. Certain weapons and effects deal more damage to armor as noted in their descriptions. Daggers, when used to slash, deal no damage to armor of any sort. Damage only applies to the armor on the hit location that was struck. Armor only protects the area that it covers. Example: if you have armor on the front of your leg, but a gap on your thigh, then a strike to the location left open by the gap would wound you, though the armor itself would be unharmed.

A valid shot:

A valid shot is anything that hits and stops or deflects at an angle. That said, there are occasionally shots that partially meet these requirements but are not valid. The best way to learn what constitutes a good shot is to ask your kingdom/group level Guildmaster of Reeves, but included here is a list of shots that do not count. These are just guidelines, and you should never attempt to use these rules to cheat your way out of a valid strike. Also remember, that in all situations the reeves call is final.

'Wiggling' – A shot (normally a stab) that misses its initial target, but is then jerked back and forth weakly in order to hit your opponent.

'Draw Cuts' – A shot that slides along your opponent with little force exerted towards your opponent. This normally happens on a missed stab. Note that a shot that hits your opponent legitimately, and then turns into a draw cut will still wound or kill the opponent as per the initial blow.

'Whipping' – A shot from a non-hinged weapon that is blocked, but the non-hinged weapon bends around the block to strike an opponent. These shots are common from exceptionally small weapon cores, or very long weapons, and should not be taken. This is not to be confused with your opponent pivoting or 'wrapping' a shot around your block using your weapon as a fulcrum. Whipping only applies when the core of the weapon itself bends around a block, enabling a shot that would have otherwise been stopped.

Equipment

Ribbons and Strips

- 1) All ribbons (also called cloths or strips) must be at least two inches wide and eighteen inches in length, and clearly visible (not hidden behind equipment or a shield) on the person or object they are applied to.
- 2) Armbands and headbands act in all ways like ribbons and must follow their rules.

Each color ribbon has a different meaning to allow quick identification.

Red:	Red Weapons and Berserking Barbarians.
Black:	Killing effects such as Touch of Death , Poison Weapon , Death Fields, etc.
Orange:	Flame effects such as Flame Arrows , Lava, etc.
Gold:	Reeves and items that may not be touched or attacked

Class ribbons for enchantments and magical effects.

Green:	Druidic Enchantments
White:	Healer Enchantments
Yellow:	Wizard Enchantments
Light Blue:	Bard Enchantments

Weapons

Besides a few magical weapons, Amtgard only allows non-explosive, non-chemical weapons that might have been in existence before 1650 AD. All weapons can be broken into three parts:

Strike-Legal: This refers to a portion of the weapon that is at least 2.5 inches in diameter (flat blades require 1.5 inches of foam on a striking surface and may not pass their tip through a 2.25 inch ring) and will not leave marks, bruises, or broken bones when used to hit your opponent. This is the only area of a weapon that counts as a legal blow. Stab-only weapons are still required to have six inches of strike-legal surface on any stabbing end for safety.

Padding: This refers to the portion of the weapon that has at least half an inch of foam over the weapon core and is designed to limit the injuries done from accidental contact with that part of the weapon.

Handle: Refers to the unpadding part of the weapon where it is held.

Weapon types

Below is a list of weapon categories and their construction requirements.

Projectile weapons: Except for javelins, projectiles may not be used to parry, block, or melee. There is no limit to the number that can be carried. Weapons not listed here and that do not fall into these categories, may not be thrown. I.e. You may not throw your sword. All these weapons do one point of damage to armor and can be blocked by weapons without penalty. Rocks hurled two-handed will do two points of damage to armor, but otherwise behave the same. Non-javelin projectiles and arrows that are not bearing enchantments or class abilities are indestructible. Projectiles and arrows that are affected by enchantments or class abilities (not to be confused with class Traits) may only be destroyed by spells or magic balls.

- a. Throwing weapons – throwing knives and axes, shurikens, darts, etc.
- b. Rocks – must be at least 1 foot in diameter.
- c. Javelins – may be used as a thrusting weapon in melee.

Dagger: A slashing or piercing weapon up to 18 inches long. At least twelve inches of its total length must be strike-legal.

Short: slashing, piercing, or bludgeoning weapons more than 18 inches up to 36 inches in total length. The pommel and handle of the weapon can be no longer than 1/3 of the weapon's total length. At least 2/3 of its length must be strike legal.

Long: slashing, piercing, or bludgeoning weapons more than 36 inches up to a maximum of 48 inches. The pommel and handle of the weapon can be no longer than 1/3 of the weapon's total length. If used to slash or bludgeon, at least 2/3 of its length must be strike legal.

Reach: slashing, piercing, or bludgeoning weapons more than 48 inches up to a maximum of 60 inches. The pommel and handle of the weapon can be no longer than 1/3 of the weapon's total length. If used to slash or bludgeon, at least 2/3 of its length must be strike legal.

Hinged: Weapons with a single articulating (chain-like) head. The chain of a hinged weapon is not a legal striking edge. Chains on these weapons must be wrapped in foam with less than half an inch of the rope exposed at any point. The combined rope and striking edge of a flail may not exceed 18 inches in length and the total length of the weapon may not exceed 36 inches.

Madu: A shield joined to a spear. The spear portion of the madu may be shorter than the normal five feet. Only usable if a class can use both a spear and a shield. If any portion of the weapon is broken, heated, or otherwise rendered unusable, all of it is disabled. Considered wooden for purposes of being targeted by spells or affecting monsters. Magic and abilities that affect any part of the madu, such as *Imbue Shield*, affect its entirety. Any shield with weapons affixed to it in any form is considered a madu and must conform to these rules

Spear: Stabbing-only weapons at least five feet in length and should not be confused with the javelin, which may be thrown (must have padding on upper 1/3 of length). Considered wooden for purposes of being targeted by spells or affecting monsters.

Staff: Bludgeoning weapon (ends may be used to thrust, but it is a bludgeon attack) of 5 ft to 8 ft that must have legal striking surfaces of at least 1 foot in length on both ends. Each end must be padded at least 1/3rd the total length of the staff. Considered wooden for purposes of being targeted by spells or affecting monsters.

Pole arm: At least five feet in length. Includes spears but may also have slashing edges (minimum 1 foot in length for a striking edge, must have padding on upper 1/3 of length). Considered wooden for purposes of being targeted by spells or affecting monsters.

Bow: A longbow does a base of four points of damage. A short bow does a base of two points of damage. Hand crossbows are considered short bows while two-handed crossbows are considered longbows. See the Archery section for more complete descriptions. Bows, crossbows, and arrows are considered wooden for purposes of being targeted by spells or affecting monsters.

Weapon Effects

A ‘Weapon Effect’ is a descriptor applied to a weapon that explains what it does. It is possible for a weapon to have multiple effects.

Red: A Red weapon, when used to slash or bludgeon, does two points of damage and can be used to destroy a shield in three hits. Great weapons (see below) are automatically red weapons. Magical enchantments and the berserk ability of barbarians can also make a weapon red. In all cases where a one-handed weapon is red, the weapon or the user must have a red strip to indicate the effect.

Great: If a weapon is five feet or more in length, has a minimum of three feet of contiguous striking surface (staves must have at least two feet at each end), and a minimum diameter of four inches (flat blades require a four inch cross section) over the entire striking surface, then it is considered Great and becomes Red when wielded two-handed in a slashing or bludgeoning manner—Never when used to stab or pierce.

Magic: Relics and weapons bearing an enchantment other than *Stun Weapon*.

Archery

The maximum limit for a bow’s pull is 35 pounds with a maximum 28-inch draw length. Crossbows are limited to no more than 450 inch-pounds. No compound bows are allowed. Broken or mended arrows are not to be used. All wooden arrows must be taped on the entire shaft. Arrows may never be used as a hand or melee weapon. The “point” of all arrows must have a diameter of at least 2.5 inches. An arrow scores hits like any other weapon. At close range (20 feet or less) bows must be no more than half drawn and two-handed crossbows may not be used. Arrows from short bows and single-hand crossbows do two points of damage to armor. Arrows from two-handed crossbows (over 20 inches in length) and longbows (any bow that is 5 ft. Or more in height when strung) do four points of damage to armor. A weapon in hand that is hit by an arrow is destroyed. If a bow is hit by a weapon, it is destroyed.

Siege Weapons

Siege weapons are extremely powerful engines of destruction that were historically used for everything from anti-personnel to tearing down walls from a great distance. The abilities and limitations of siege weapons are as follows:

- 1) A melee siege weapon will kill any person or destroy any object it strikes regardless of armor. Is considered engulfing. Counts as one hit against invulnerability. Will stop **Fight After Death**.
- 2) A projectile siege weapon that fires a single projectile at a time, such as a single boulder or bolt, strikes exactly like a melee siege weapon except that it is also stopped by the enchantment *Protection from Projectiles*. A monk may not block this type of siege weapon projectile. Will stop **Fight After Death**.
- 3) A projectile siege weapon that fires multiple projectiles at a time, such as a grapeshot catapult, counts as firing Red projectiles. A monk may block these projectiles as normal. *Protection from Projectiles* stops these. Will not stop **Fight After Death**.
- 4) A siege weapon that fires projectiles may not be used within 20 feet unless its operators have the ability to “half-draw” the weapon.
- 5) A siege weapon is a large, tough object that is hardened from casual attack. They are considered to have ten points of armor and are destroyed when all armor is lost (i.e. Ten hits from a one point weapon, five hits from a two point weapon, etc). Arrows have no effect on siege weapons with the exception of a **Flame Arrow**, which will do five points of damage to the siege weapon. Melee siege weapons and single shot projectile siege weapons will destroy another siege weapon on a single hit. Multiple projectile siege weapons deal damage to siege weapons as per normal. A siege weapon operates as long as it has at least one point of armor remaining. A *Mend* will repair one point of armor over all (siege weapons do not have sectional armor). Destroyed siege weapons may not be retrieved from base.
- 6) Siege weapons require at least three people to operate. Those people may be involved in any operation of the engine but may not be fighting, be **Berserk**, casting magic, using activated class abilities, or move more than ten feet away. A siege weapon with less than three people crewing it may not be used. Some monsters are exempt from this rule. Members of the siege crew may leave at any time and continue playing as normal.
- 7) You may only have one siege engine per twenty people on a team.
- 8) Siege weapons should have a historical or fantasy counterpart that they mimic in form and function. Siege engines may only be direct impact weapons such as catapults, ballistae, etc. You may not use siege engines that mimic area of effect attacks such as firebombs or Greek Fire. You may not use siege weapons that mimic gunpowder effects such as cannons.

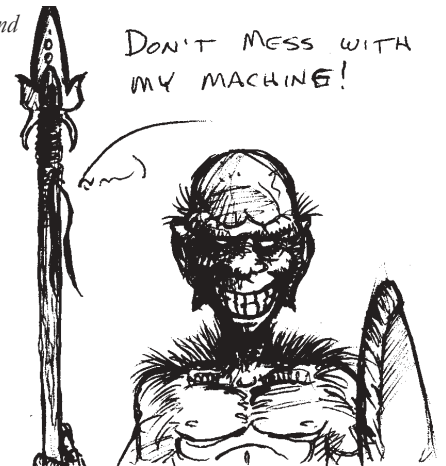

Shields

Shields are considered wooden for purposes of being targeted by spells or monster abilities. All shield measurements are the exterior surface area on a flat plane.

- 1) Bucklers are a type of small shield that is strapped to a forearm instead of wielded in a hand. Anyone allowed to use a small shield may use a single buckler.
Note: This does not allow use of both a shield and a buckler.
- 2) Shields struck by effects that break shields (such as Red weapons) retain this damage until repaired, therefore receiving two such strikes from one player and one such strike from another player ten minutes later is sufficient to destroy the shield.
- 3) All shields must either be strapped to an arm or gripped in a hand. A blow that strikes a non-wielded shield strapped to a player, such as a shield slung across a back, is considered to strike the player as if the shield had not been there. A player may only wield one shield at a time.
- 4) A large shield is no larger than eight square feet.
- 5) A medium shield is no larger than five square feet.
- 6) A small shield is no larger than three square feet.
- 7) Non-round shields may not be wider than two feet.
- 8) Round shields may not be wider than three feet.

Equipment Construction

Weapon Construction Notes

What is a safe weapon? A safe weapon is one that will not leave marks, bruises, or broken bones or teeth when it strikes a person. If your weapon hurts you when you are struck, it is not safe. The entire surface of a weapon must be padded as per the weapon descriptions in **Weapon Types** above. Cross-guards must be padded. For a base the best things to use are carbon/graphite rods (such as from non-metallic golf clubs), kite spar, bamboo, PVC tubing or fiberglass. Other materials will be checked for safety on a case-by-case basis. Metal and wooden cores are not acceptable and will never be considered legal.

Use good, stiff foam to pad your weapon. Ensolite™, a type of closed cell foam, is good to pad the base. Funnoodle™, a preformed pool flotation device, is a quick and easy alternative to Ensolite™, however it wears out much faster. Foam is best cut with a razor or sharp scissors. Stick the foam to the shaft with adhesive glue or tape. Weapons must be covered in a durable, opaque cloth.

Weapon tips (points, guards, pommels, etc.) And striking surfaces must be at least 2.5 inches in diameter (flat blade weapons must not be able to pass their tip through a 2.25 inch diameter ring) in diameter. The ends of all weapon cores must be blunted by capping them with a layer of foam and tape. Stabbing weapons should include extra padding on the tip to ensure safety. Magic components used in combat (magical balls, etc) must also be padded and be at least 2.5 inches in diameter.

Sword construction tutorial

(with Funnoodle™ or Camp-pad foam):

- 1) Use a length of Fiberglass, Kite spar, PVC, or a golf shaft for the core. Remove all sharp edges and points from both ends of the core.
- 2) Cap both ends of the core with alternating layers of tape and foam until the cap is secure and decidedly dull. Cover the pommel with enough closed cell foam to ensure that it is at least 2.5 inches in diameter. Note that all pommels must meet this minimum size requirement regardless of your specific fighting style.
- 3) a. To make a flat blade, sandwich the core between several layers of camp-pad foam.
b. To make a round blade, you can use a piece of Funnoodle™ that has a factory hole in the center, and cut it to be the length of the blade. If your core moves back and forth within the hole, you can tape a long strip of camp pad foam to the shaft to reduce the noise and prolong the life of the blade. Tape the base of the Funnoodle™ to the shaft very well. Fiberglass strapping tape is recommended for strength and weight.
- 4) Tape several pieces of closed cell foam over the top of the sword with fiberglass strapping tape. You should have at least 3 layers of closed cell foam (1.5 inches) on your stabbing tip (and even more for a two handed stabbing weapon, such as a spear).
- 5) For the cover, choose a light, durable fabric. Cut it to length plus three inches, and outside diameter plus one inch.
- 6) Fold the fabric across and sew the side and top.
- 7) Roll the cover like a stocking, and then roll it down the sword.
- 8) Secure the cover to the hilt with tape.

Shield Construction

Shields should be made from light, firm materials, should be well padded, and require a cloth cover. Hard edges may not be exposed. Good materials to use include substances with some give, such as plywood and high impact plastics. An interesting alternative is to use a plastic snow toboggan, which will produce a light shield that requires less padding. Another popular shield design uses only a thick foam disc, thus negating the need for additional padding (just a cloth cover). Be careful with these however, as not all foam materials are the same. Plank foam is a particularly durable and safe variety that makes for an excellent shield; while foam such as what 'boogie boards' are made of is effectively a rigid material and requires padding. Thick strips of leather make good arm straps. When using a non-foam shield, bolts should be attached with the head affixed to the exterior of the shield with washers, and then heavily padded with foam. All rigid-core shields must either have foam folded over the edges or have the shield edges recessed into the foam. All rigid-core shields must be covered with a layer of foam that is at least 1 inch thick on the face, and 1.5 inches on the edge. Shields must be at least as safe as the weapons we use.

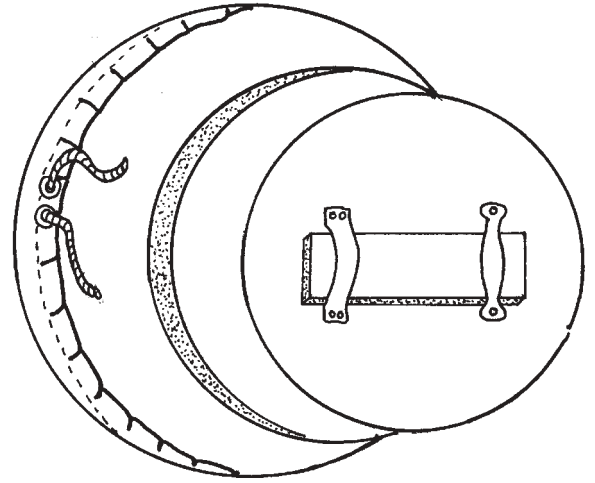

Arrow Construction

Arrows are generally fragile and are often broken under the constant rigors of fighting. Arrow shafts made from graphite offer a flexibility and resilience not found in their aluminum or wooden counterparts. Wooden arrows must be taped along their entire length. All arrowheads must be removed from the arrow, and the base of the arrow at the tip must be built up with a sufficiently strong material to at least the diameter of a penny, which is used to cap the arrow. Arrows may not be drawn beyond 28 inches, and must have a stopper in place if they are longer. Arrows must have a minimum of 2 inches of closed cell foam on the tip, and it must be at least 2.5 inches in diameter. It is suggested that you also incorporate a layer of open cell foam to reduce the recoil of the arrow when it strikes a solid surface. Arrow fletching and nocks must be in good repair, and arrowheads should be checked regularly for degrading foam. All arrows must be clearly labeled with their owner's name on the shaft. Properly colored head covers may be used in lieu of ribbons.

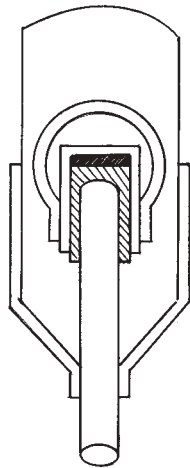
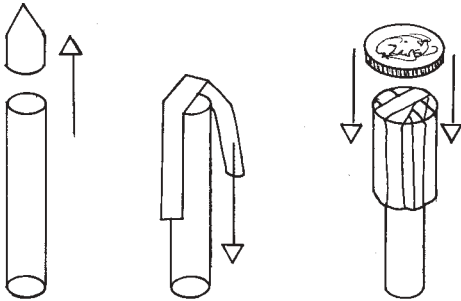

Projectiles

A blow by any part of a throwing weapon, boulder or rock counts as a hit; so all parts of these weapons need to be strike-legal. Javelins must strike point first to count as a hit, but must have courtesy padding along their entire length. All projectiles must be at least 2.5" in diameter. Projectiles, with the exception of javelins, may not have solid cores. Materials you may use for projectile cores include foam, sweatshirt material, and other soft, non-granular materials. Pennies, batteries, sand, and the like may never be used as cores.

Armor Construction

The Monarch, Champion and Guildmaster of Reeves rate armor. Damage to armor only applies to the hit location that was struck, and armor only protects the area it physically covers. Damage that exceeds the armor value (i.e. Arrows, berserk barbarian weapons, great weapons, etc.) Wounds or kills the target. Armor that is mixed (multiple types of armor covering the same body area) will be averaged. Armor may not be stacked or layered to increase or add value unless explicitly stated in these rules. Armor worn under tabards or garb must be partially visible, and must be announced if asked. Armor should weigh close to actual historical standards to receive full value. Armor only protects the area it physically covers. Straps and other such material that hold your armor on do not count as part of the armor, for either coverage or averaging purposes, unless they are specifically built as such. Example: the leather strap across your back holding on your steel breastplate does not protect you from blows.

Standard criteria are 16-gauge steel for metals and 1/16 inch for leather. All armor must be safe, with no protruding edges that could injure someone. Armor values may never be greater than 6 points unless you are a 6th level warrior or certain monster classes. Armor is rated as the material that it most resembles, thus plastic and other non-metallic armors can never be disguised nor passed off as plate or chain mail.

These are the base armors:	Points
Padded cloth, quilted cloth, light leather 1/16 inch	1
Heavy leather 3/16 inch	2
European '4 in 1' chain mail	3
Augmented chain, riveted chain	4
Brigandine, double mail, or lamellar	5
Plate	6

These materials can be added to increase non-metallic armor values:

Cuir bouilli	+1
Studs / Rings	+1
Scales	+2

To increase the value of any form of chain mail:

Full padded gambeson or arming coat	+1
-------------------------------------	----

Construction additions and subtractions:

Non-authentic materials	-1
Poor workmanship	-1
Shoddy and/or artificial appearance	-1
Heavy gauge material	+1
Superior construction	+1

Armor Descriptions:

Padded cloth: four layers of cloth sewn together.

Quilted cloth: two layers of cloth with padding in between sewn together.

Light leather: leather of at least 1/16" thickness.

Heavy leather: leather of at least 3/16" thickness.

Chain armors: must be at least 16-gauge, with an internal diameter of, at most, 3/8 of an inch. Regular chain armor consists of butted links.

Augmented chain: chain augmented in some fashion from the standard '4 in 1,' such as plates attached to each other by chain, or any of the Persian/Chinese weaves.

Riveted chain: chain in which all the links have been individually riveted together.

Lamellar: plates that have all been joined in an overlapping fashion by cord or chain link.

Brigandine: closely spaced or overlapping plates riveted between two layers of leather.

Double mail: '8 in 2,' or a mail in which a standard pattern is woven with two rings replacing every single ring.

Plate: solid metal armor with riveted metal articulations to increase mobility. Example: Lorica Segmentata.

No armor list can be completely exhaustive, and armors not mentioned should be ranked according to their composition (metallic vs. non-metallic) and their protective value relative to other armors in the table.

Armor Definitions

Plates are made of at least 16-gauge steel and must be attached to each other or a backing in such a way that all four edges or corners are held into continuous rigid contact with each other or the backing. Plates may alternately be made of 3/16" hardened leather and receive a -1 to the total armor value.

Cuir bouilli is the process by which leather is hardened using wax or other treatments to produce significantly harder leather.

Studs are composed of metal, and must be no more than 1.5 inches apart to receive the bonus. Studs may not be added to metal armor.

Rings are composed of metal (not to be confused with chain mail), and must be at least 1/8 inch thick, have an internal diameter of at least 1 inch and no greater than two inches, and be placed no further than 1.5 inches apart to receive the bonus. Rings may not be added to metal armor.

Scales are composed of metal (+2) or 3/16" hardened leather (+1), and must be overlapping. Scales may not be added to metal armor. Scales need only be attached to the armor along one edge.

Gambeson (sometimes referred to as an arming coat) resembles a quilted, close fitting tunic that minimally extends from the thighs of an individual to their elbows, excluding their head and neck. If worn under any type of chain mail, the wearer will receive a +1 bonus to the area that the chain mail covers. The gambeson may not be modified to increase this value. A gambeson must be the equivalent of at least quilted cloth with cotton batting padding in between the layers, and must cover the entire area of the hit location under the chain in order to grant a bonus.

Armor Modifiers:

Non-authentic materials refer to materials that were not in use to create armor at the time, such as plastic. For comparison of metals, 16-gauge steel is the standard weight and toughness, so lighter or softer metals, such as aluminum, will incur this penalty, while stainless steel will not. Subtractions for inauthentic material may never exceed -2, though completely inappropriate materials may receive no points (i.e. Aluminum foil, cardboard, etc).

Poor workmanship refers to an inexperienced or incomplete assembly by the creator – the use of non-period items such as hot glue, tape, or shoestrings to hold the armor together. Subtractions for poor workmanship may never exceed -4.

Artificial appearance refers to the overall appeal of the armor and its ability to accurately resemble historical armors. Subtractions for appearance may never exceed -2.

Heavy gauge material is material that exceeds the 16 gauge standard for rings or plates.

Exceptional craftsmanship is reflected in the overall construction and function of the armor as compared to other armors of its type, and is awarded on a case-by-case basis. Bonuses for construction may never exceed +2.

Armor in action:

Example 1: A person with two points of torso armor that covers his chest and back is struck in the back with a regular sword:

One point of armor is removed from the torso armor, leaving one point on the armor covering the chest and back (chest and back are included together under torso armor).

Example 2: A person with two points chest armor and no back armor is struck in the back with a sword: Person is dead.



Battlegames

Subduals and Prisoners

During class battles, prisoners may be taken by surrendering or by being rendered “unconscious” by a killing blow (torso or second limb shot) preceded by the word “subdue.” The person will then be unconscious for 60 seconds. The prisoner may be subdued up to 5 times. Any more hits will result in his death. Armor negates a subdual blow and instead takes damage as normal from the blow. If this damage is sufficient to pass through the armor, then the target is still affected by the subdual blow. A Subdual blow striking a person who is unaffected by Subdual does not wound or kill. Stabbing-only weapons or stabbing with a slashing weapon may not be used to subdue. A subdual blow to a limb will render that limb useless for a 60 count. A prisoner’s equipment must be kept within 10 ft. Of him and cannot be destroyed. Rescued prisoners must still count the required time before they are considered recovered. Subdual blows cannot be healed.

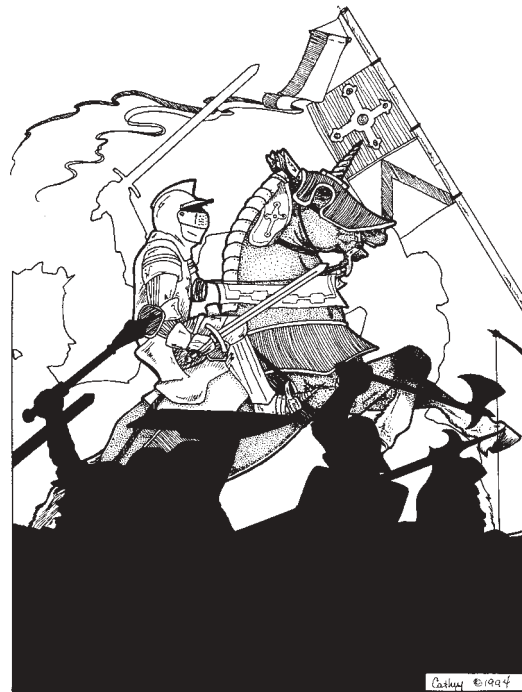

Deaths and Lives

Immediately remove yourself from impeding play on the battlefield once you have died. If you want to get into the spirit of things, then fall down and scream. Make it dramatic. Reeves may give you a bonus for a good death. Then report to nirvana. The reeve in charge there will take your name and record your time. Deaths are for 5 minutes though a bonus will subtract 2 minutes and a penalty will add 2 minutes. The number of lives you get varies with level and class. You are out of a battle once you have expended your last life and left the field. When returning to life from nirvana you must return to your base and announce ‘Alive’ so that it is audible out to 50 feet before reentering the battle. Dead persons on the field must hold their weapons over their heads. If the battlegame does not call for a nirvana reeve, one must sit down in nirvana for a 300 count before returning to life at one’s base. Most battlefield effects will not work on a dead person once he has left of his own choice from where he died, with the obvious exception of not impeding play. Effects that will function on dead players who have moved from where they died are noted as doing so in their descriptions. Dead players (provided they are not affecting or impeding play) may stay on the field as long as they want. A person may voluntarily take a game death at any time, but must immediately go to nirvana and may not be raised from the dead in any manner unless *Summon Dead* is cast upon them first. Dead players may not move if they are currently the target of a magic or ability that affects dead players such as **Steal Life** or *Resurrect*.

Holds

When a hold is called all players must stay where they are and be quiet. No tactical maneuvering is allowed and weapons may only be collected if a reeve gives permission. If you really do get hurt, yell “hold.” Remove yourself from the battle and reenter behind your own lines once you have recovered. Deliberate faking of a game death or real injury is not allowed. Battlefield participants should only call a hold for injuries or when a potentially dangerous situation arises such as a seven year old child straying onto the battlefield. If you are involved in a dispute then go find a reeve or remove yourselves from the field until the issue is resolved.

Battlegame Rules:

- 1) Switching classes or sides during a battlegame is not allowed unless specified by the scenario or by a reeve.
- 2) Never handle anyone’s personal property without first having their permission.
- 3) There cannot be more than 1 bow to every 5 people on a side – round fractions up.
- 4) Each side may only have one wizard, healer, druid and bard per ten people, rounding fractions up. Therefore, a team with seventeen people may have no more than two of each magic-using class.
- 5) Players who break the rules may be removed from the game by a reeve.

Battlegame Restrictions:

The following activities are strictly forbidden:

- 1) Maneuvering or engaging during a hold.
- 2) Striking at reeves or non-combatants.
- 3) Calling a hold to retrieve spent items or derive other advantages.
- 4) Trying to influence a game while you are dead.
- 5) Deliberately mimicking an ability that you do not currently have, such as casting a “pretend” *Finger of Death* as a barbarian. Grand standing and bluffing is fine, as long as it can’t be confused with a real ability.
- 6) Deliberately mimicking an ability that you do have, such as pretending to cast a spell but using the wrong wording.
- 7) Using rules loopholes or gray areas to derive an advantage on the battlefield.

Game Etiquette:

While not absolutes, the following conditions have stood the test of time and should be observed:

- 1) Do not use a hold to gather or retain spent equipment or valuable game items. A reeve or the other team may grant a person the opportunity to pick up spent equipment if they are simply asked.
- 2) Do not use a hold to avoid a death or get out of a bad situation.
- 3) While it is honorable to return the other team's spent equipment (magical balls, weapons, expended arrows, etc.), it is not mandatory. Don't delay or stop play to return equipment. Similarly, don't attack someone who is being kind enough to return your own team's items.
- 4) As stated before, players should remove themselves from the field when discussing disputed blows or rules. This is not always practical in the immediate heat of the moment. If you see a dispute, do not engage or strike at those involved. By the same token, don't use the excuses of returning equipment, a headshot, or resolving a dispute to save yourself when the enemy has you dead in his sights. **Example:** You are accidentally struck in the face, and simultaneously cleaved in two from behind by another opponent; you are still dead.

Garb:

Each class has its own particular garb parameters. In addition, there are certain other garb elements that denote special positions. Note that all battlefield participants must be in "period" garb (tunic, robe, armor, etc.):

- 1) White belts (any belt more than 25% white), unadorned chains, and spurs are reserved for knights and may not be worn by others. A knight may also choose to trim a knight's white belt with a color particular to that order of knighthood: Gold for Crown, Silver for Sword, Red for Flame, and Green for Serpent.
- 2) Red belts (any belt more than 50% red) are generally only worn by squires.
- 3) Black belts with silver trim are generally only worn by men-at-arms.
- 4) The Phoenix is the symbol of Amtgard. White and Black Phoenixes are reserved for knights. Gold Phoenix on a red background is reserved for Warlord. Otherwise, the phoenix is generally only worn as part of kingdom heraldry.
- 5) A diagonal slash of a guild's distinct color, worn on a belt, baldric or tunic, is the mark of a class master.
- 6) Guildmasters are entitled to wear favors marked with the symbol of their guild.
- 7) The use of crowns and coronets is reserved for royalty and nobility, although their retainers may wear the symbol of a crown on their garb.
- 8) Most companies and many individuals choose to register their personal symbols and colors. While not specifically disallowed, it is considered bad form to use another's coat of arms without his agreement. Personal symbols and colors should be registered with the Guildmaster of Heraldry and the Prime Minister.
- 9) Single color belt favors are indicative of a fighter's relative standing within the fraternity of Order of the Warrior.
- 10) The garb of a page is a yellow belt (not a sash as per wizard) and is generally not worn by others. A non-fighting page must also wear a gold "enchantment" strip if on the field.
- 11) The use and application of good garb is important in creating the correct mood of the Amtgard battlegames and events. All members must be garbed in a "period" fashion. Newcomers should have their own garb (and weapons) within a month of having first attended Amtgard. It is easy and inexpensive to fashion a T-tunic or tabard, and plenty of people are willing to help. If you have questions about garb or any area of the rules, then all you have to do is ask.
- 12) For the purpose of determining what class people are playing, class sashes must run diagonally across the chest from one shoulder to the opposite hip. They must be at least two inches wide.

Non-Fighting Types

If you do not want to fight but wish to participate in a battlegame there are a few classes that do so:

Reeve – The garb is a gold tunic, headband, or sash. The reeve is a referee for the battlegame. The reeve should be impartial, fair, have a good eye, and be well versed in the rules. The reeve has the last say in any decision in a battlegame. The reeves do not fight and should not be purposefully hit or touched in an offensive manner. The Guildmaster of Reeves shall deal with biased, unfair, or incompetent reeves.

Page – Garb consisting of his master's device is optional. Non-fighting pages may retrieve spent equipment, but may not retrieve or carry new or extra equipment. Must wear a gold enchantment strip around right wrist.

Color – Garb is encouraged. It is not a class, yet includes everyone else who wishes to participate in the mood and ambiance of Amtgard. Examples include minstrels, water bearers, serpent knights, and many others.

Arts and sciences guilds – Artisans, smiths, garbers, etc.

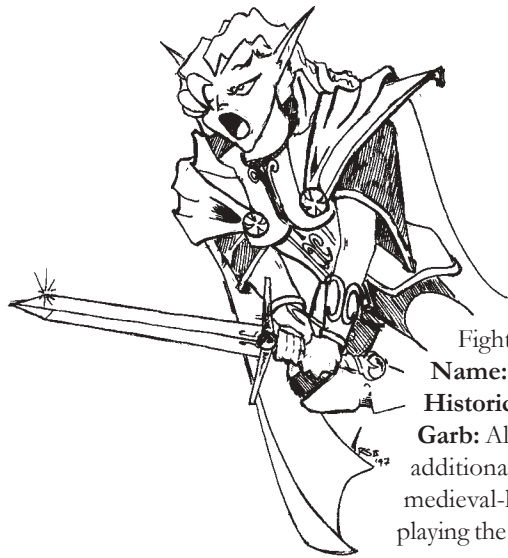

Fighting Classes and Abilities

Fighting classes are listed in the following manner:

Name: The name of the class.

Historic Examples: This lists historical or fantasy examples of each class plus a brief overview.

Garb: All participants must dress in a tunic, robe, armor or other period garb. This lists additional garb that is required to denote playing the class. You are expected to dress in medieval-looking garb in addition to this class specific garb. Failure to do either will result in playing the peasant class.

Requirement: A few classes list experience requirements. If you do not meet these requirements you may not play nor gain credits in that class.

Armor: This lists the maximum point value of armor the class may wear. For example a scout can wear three points of armor. Thus, he could wear average-quality chain, exceptional-quality leather, or poor-quality augmented mail. Note that you can always wear armor with a point value higher than you are allowed use of, but in these cases the armor simply gives you the maximum allowed for your class. Example: a scout wearing full plate still only gets three points from it.

Shields: Largest size shield available to a class.

Weapons: This lists what types of weapons the class can use.

Immunities: Lists what the class is immune to. If a creature or player has immunities, these take precedence over losing points of invulnerable armor or normal invulnerability. Immunities never extend to any sort of non-invulnerable armor or equipment of any sort. For example, scouts are immune to *Lost*. If *Lost* is cast on a scout who has a *Protect* on, he does not lose a point of invulnerability from it. For purposes of immunities, traps are any magic or ability with the word "trap" in the name, and poisons are any ability or magic with the word poison in the name.

Lives: This lists the number of lives the class has.

Limitations: Some classes have restrictions. For example, barbarians are restricted from wearing enchantments.

Traits: Traits are class attributes that function all of the time without activation being required. This includes such things as extra lives and the ability to wear extra armor. Traits are denoted with a (T) and are always non-magical in nature.

Abilities: Powers or skills that must be activated to be used. Abilities are denoted as either Magical (m) or Extraordinary (ex). Unless otherwise specified, class ability enhanced equipment cannot be used except by the player who enhanced the equipment. For instance: a warrior cannot loan his Improved Weapon to another player, even another warrior.

Credits and levels

If you wish to fight or participate in a battlegame, you must conform to one class for each game. A person may advance in level in a class after having the requisite credits and passing a class test administered by your class Guildmaster. Only one attendance credit may be given on a single day. You must play the class you wish to gain credit in. If no class is played but fighting takes place, you may take a warrior credit. All classes gain new abilities and levels at the following rate:

- 1st Level - less than 13 credits of experience in that class
- 2nd Level - at least 13 and less than 25 credits of experience in that class
- 3rd Level - at least 25 and less than 37 credits of experience in that class
- 4th Level - at least 37 and less than 49 credits of experience in that class
- 5th Level - at least 49 and less than 61 credits of experience in that class
- 6th Level - 61 or more credits of experience in that class

Standard Classes



Anti-Paladin

These are the standard bad guys of legend. Almost any adversary in a stock fantasy movie can qualify as an Anti-Paladin, but historical cases abound – ranging from Vlad Dracul's persecution of Turkish prisoners to Mongol warlords boiling opposing chieftains alive.

Examples: The Kurgan, Mordred, the Black Knight, the Nazgul, Tamerlane, Sir Francis Dashwood

Garb: Must wear a white belt and have a Black Phoenix openly displayed on clothing or armor.

Requirement: Must have been a Knight for twelve weeks

Armor: 4 points

Shields: Large

Weapons: All Melee, javelins

Immunities: Control

Lives: 4

Abilities & Traits:

Levels

1st None

2nd

Touch of Death (ex) (1/game)

3rd

Poison Weapon (ex) (1/game)

4th

Steal Life (m) (1/game)

5th

Innate Ability (choose one before game starts):

a.

Poison Weapon becomes 2/game

b.

Fear (m) 2/game

6th

Immunity: Flame

Touch of Death becomes 1/life

Archer

Everyone knows the legend of William Tell, and that story has a basis in fact in the Welsh Archers who long resisted British rule before making the English longbow world-famous. Other outstanding examples include the kyudo archers of Shogun-era Japan, and the Sioux Dog Soldiers.

Examples: William Tell, Odysseus, Paris of Troy, Robin Hood, Bard of the Dale, the Ettrick Foresters, and Minamoto Tametomo

Garb: Orange sash (plus must carry a bow or crossbow)

Armor: 3

Shields: None, initially

Weapons: Dagger, short, long, long or short bow

Immunities: None

Lives: 4

Abilities & Traits:

Levels

1st **Bowyer** (ex) (1/life)

2nd **Stun Arrow** (1/reusable) (T)

Flame Arrow (ex) (1/reusable) (T)

3rd **Accuracy** (T)

4th Total lives increase to 5 (T)

Armor-piercing Arrow (1/reusable) (T)

5th May now use small shields (T)

6th **Penetration Arrow** (1/reusable) (T)

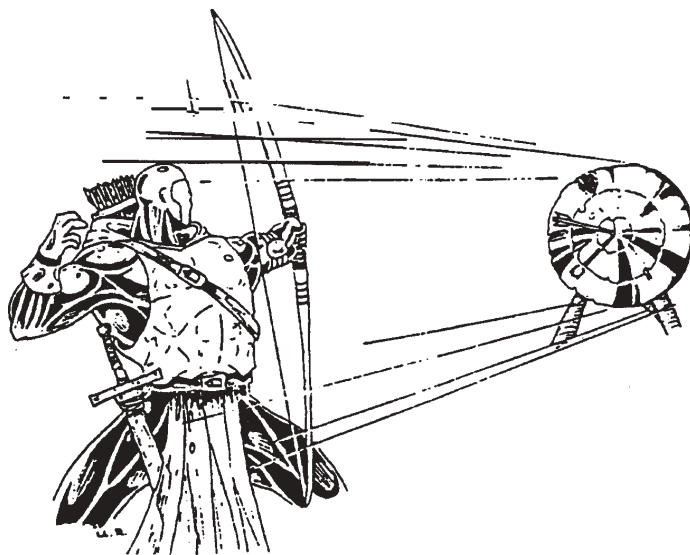

Assassin

Assassins were once so powerful in the Middle East that Hulagu Khan had to storm their mountain fortress when they demanded tribute. Renaissance Italy and its setting of political intrigue made the courtly killer somewhat of an art form.

Examples: The Ninja, the Borgias, the Jackal, Hassan-I-Sabah, Sir Francis Walsingham

Garb: Black sash plus must wear a mask or concealing face paint. Mask may be worn around neck.

Armor: None initially

Shields: None initially

Weapons: Dagger, short, long, throwing weapons

Immunities: None

Lives: 4

Abilities & Traits:

Note: Each time an assassin plays in a battlegame, he must choose which abilities he is using for the entire battlegame. He can switch them between each battlegame as he sees fit.

Levels

1st No additional abilities

2nd **Innate Ability** (choose one):

- May use a short bow or hand crossbow (I)
- Poison Weapon** (ex) (2/game)
- Trap** (ex) (1/game)

3rd **Innate Ability** (choose one from this list or any lower level ability not already taken):

- Touch of Death** (ex) (1/game)
- Teleport** (ex) (2/game)
- Antidote to Poison** (ex) (1/life)

4th Up to two points of armor may now be worn (I)

5th **Innate Ability** (choose one from this list or any lower level ability not already taken):

- May now use small shields (I)
- Assassinate** (ex) (2/game)

6th **Innate Ability** (choose two from this list or any lower level abilities not already taken):

- Take **Teleport** again (must have already been taken once) **Teleport** becomes (1/life)
- Take **Assassinate** again (must have already been taken once), **Assassinate** becomes (1/life)
- Take **Poison Weapon** again (must have already been taken once), **Poison Weapon** becomes (1/life)
- Take **Trap** again (must have already been taken once), **Trap** becomes (1/life)



Barbarian

The Chinese, from ancient periods onward, have considered everyone else to be Barbarians, and oddly enough it is the Eastern tradition from India to China that gives us the image of civilization defending itself against the nomadic hordes of such peoples as the Tartars, White Huns, Seljuk Turks, and other steppe tribes.

Examples: Conan, Yellowbeard, Leif Eriksson, Hannibal Barca, Attila the Hun, Alaric the Vandal, the Voivodes

Garb: Blues and browns, furs and leather. Must wear a fur or leather sash that cannot reasonably be mistaken for the sash of any other class.

Armor: 2 points

Shields: Large

Weapons: All melee, short bow, projectile weapons

Immunities: Subdual

Lives: 3

Limitations: Cannot carry enchantments. May not use relics except Heimdall's Horn.

Abilities & Traits:

Levels

1st **Berserk** (ex) On last life

2nd Total lives increases to 4 (I)

3rd **Fight After Death** when Berserk (I)

4th **Powerful Blows** (I)

5th Total lives increase to 5 (I)

6th Total lives increase to 6 (I)

Berserk on last two lives

Bard

Bardic history is mostly tied in with the early oral tradition of the druids and Norse skalds. Medieval Europe does give us a case of actual singing knights, many of them female, from the independent French province of Aquitaine before it was crushed by the Papacy.

Examples: Sarafin, William Shakespeare, Alan O'Dale, Homer, Scheherazade, Circe, Bragi, Snorri Sturluson

Garb: Light blue sash, plus must carry a musical instrument

Armor: None

Shield: Medium (will subtract from magic points)

Weapons: See the Magic section for a listing of weapons used. Weapons subtract from the Bard's magic points

Immunities: None

Lives: 4

Abilities & Traits:

Bardic Charm: Some monsters may be immune to the control school, but not bardic charm. Bardic charm is any control magic that is cast by a bard (even those bought with *Voice*).

Magic-user: Bards are magic-users and gain magic at each level. See the Magic section for more details.

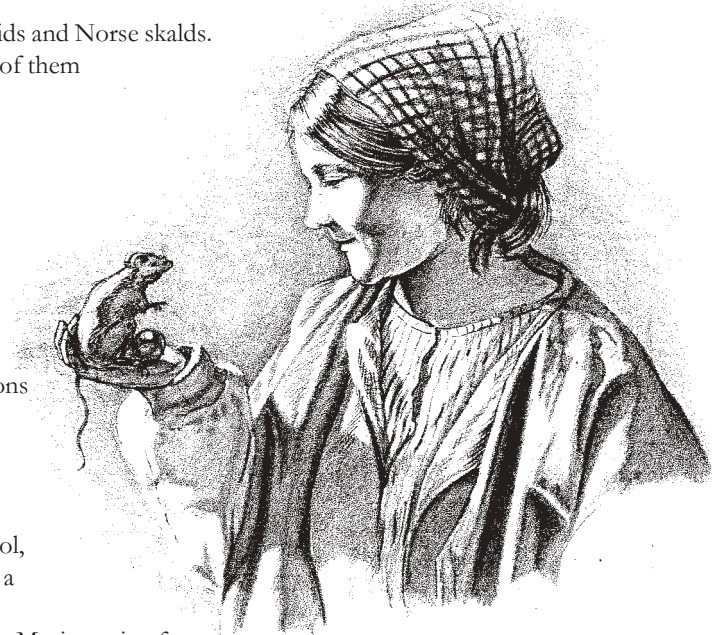

Druid

Neolithic anthropological evidence indicates a strong tradition of matriarchy and mother worship in Central Europe, the origin of the proto-Celtic Beaker and Axe peoples. It is highly possible that many if not most early Druid-types were priestesses rather than priests.

Examples: Galadriel, Johnny Appleseed, Lady of the Lake, Cathbu, Tom Bombadil, the Green Knight

Garb: Brown sash

Armor: None

Shield: Small, will subtract from magic points

Weapons: See the Magic section for a listing of weapons used. Weapons subtract from the Druid's magic points

Immunities: None

Lives: 3

Abilities & Traits:

Magic-user: Druids are magic-users and gain magic at each level. See the Magic Section for more details.

Levels

- 1st No additional abilities
- 2nd Number of lives increases to 4 (I)
- 3rd **Pass Without Trace** (ex) (2/game)
- 4th Immunity: Poison
- 5th Immunity: to magic from fey monsters
- 6th Immunity: Control

Healer

This image has been somewhat forged between clerics and the “hedgemagickers” that preceded Christianity. Our modern view of the fighting “Healer” stems from early medieval clerical use of bludgeoning weapons, so as not to break the implied Biblical prohibition against drawing blood.

Example: Hippocrates, Chiron, Elrond, Goldmoon, Archangel Raphael, Galenus, and the Hospitallers

Garb: Red sash

Armor: None

Shield: Medium, will subtract from magic points

Weapons: See the Magic section for a listing of weapons used. Weapons subtract from the Healer’s magic points.

Immunities: None

Lives: 4

Abilities & Traits:

Magic-user: Healers are magic-users and gain magic at each level. See the Magic Section for more details.

Monk

Shaolin and Buddhist temples manned by fighting Monks who learned to fight with their hands and strange implements when their warlords forbade them to use swords are the classic image of this class. However, many Asiatic and American tribes had strong traditions of wrestling, and the Shogun-era Japanese had a plethora of armed warrior Monks whose wrath was feared by even the Emperor.

Examples: Bruce Lee, Qui Chang Kane, Dread Pirate Roberts, the Bloodguard, Benkei, Pachomius, the Sohei

Garb: Gray sash

Armor: None

Shields: None

Weapons: Dagger, short, long, pole arm

Immunities: Gained at later levels

Lives: 4

Abilities & Traits:

Levels

- 1st **Heal** (m) (1/life, Self only)
- Missile Block** (I)
- 2nd May now use throwing weapons (I)
- Immunity: Poison
- Transfer Life** (ex) (1/game)
- 3rd Immunity: Control
- Touch of Death** (ex) (1/game)
- 4th **Greater Missile Block** (I)
- Banish** (m) (1/life)
- 5th **Banish** (2/life)
- Immunity: Death
- Sanctuary** (ex) (1/life)
- 6th Immunity: traps
- Heal** (2/life, Self Only)

Monster

Monster is a special class. Credit in Monster can only be taken twice a month, but as you increase weeks in Monster, you increase it for ALL monsters. Thus if you have 13 weeks in Monster, you can play a 2nd level Monster of any type.

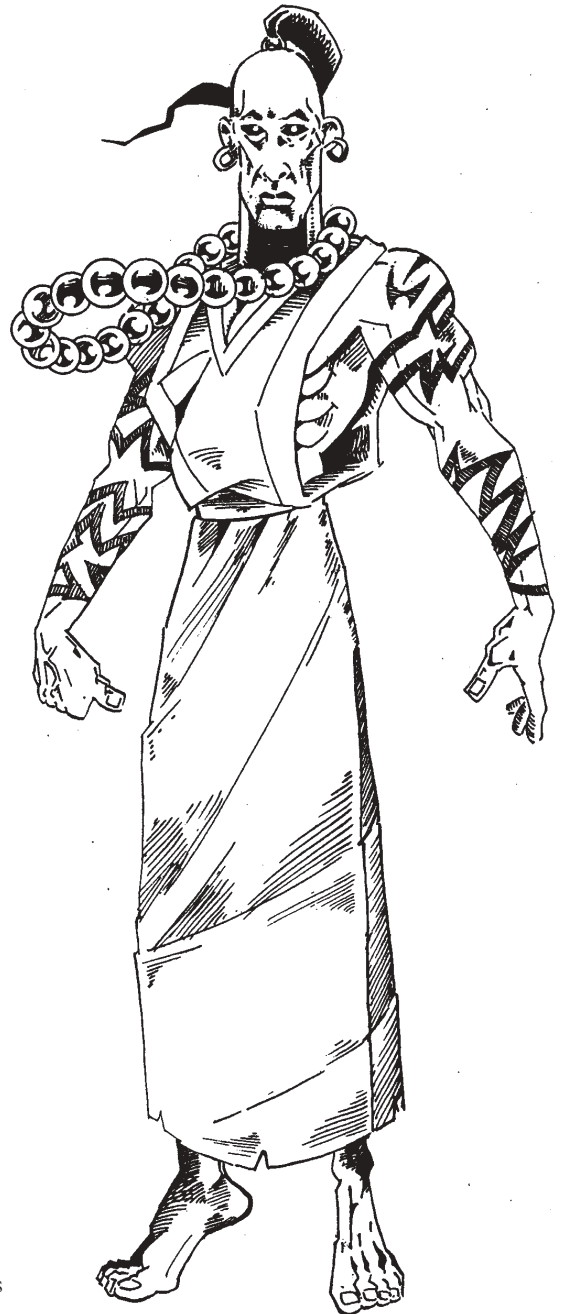

Paladin

The perfect good guy comes to save the day. Paladins exist in the myths and legends of all cultures. Be it the Geatlander Beowulf slaying Grendel or the Norse god Thor battling the Midgaard Serpent, Paladins have been with us since prehistory.

Examples: Joan of Arc, Galahad, Bovide, King Arthur, Roland, Percival, the Twelve Peers of France, Don Quixote, Arcite, Palamon, Dietrich von Bern

Garb: Must wear white belt and have a White Phoenix openly displayed on clothing or armor

Requirement: Must have been a Knight for 12 weeks

Armor: 4 points

Shields: Large

Weapons: All melee, javelins

Immunities: Subdual

Lives: 4

Abilities & Traits:

Levels

1st None

2nd **Heal** (ex) (1/game)

3rd **Extend Immunities** (m) (unlimited)

4th **Resurrect** (ex) (1/game)

5th **Innate Ability** (choose two before game starts):

a. **Heal** becomes (1/life)

b. **Resurrect** becomes (2/game)

d. **Awe/Fear** (m) (2/game)

6th Immunity: Death



Peasant

Peasants are players who do not have appropriate garb for a class but still want to play. You may take credits in peasant but they have no levels, so no advantages are gained from doing so.

Garb: None

Weapons: Dagger, short

Armor: None

Shield: None

Lives: 4

Limitation: Is only played if a player does not have garb and equipment for any other class. Must be played if appropriate garb is not worn.

Raider

A new player can play the raider class during the first four weeks of his attendance.

A new player can take credit his first four weeks as a warrior even if he plays raider.

A player must always have the basic garb requirement (the sash) to play a normal class, even as a new player. However, new players are not required to have full garb (tunic, etc) to play a class. Players who have four or more total credits are no longer considered new players and should have full and appropriate garb. Players without appropriate garb must play the peasant class.

Garb: Black and white or headband.

Requirement: May only be played if the player has a combined total of four credits or less

Weapons: Dagger, short, long, reach

Shield: Large

Armor: None

Abilities & Traits:

a. Have two points of *Protect* on them each life. Cannot be dispelled. (I)

b. They and their equipment are immune to all non-spirit magic. (I)

c. Their equipment is indestructible by any means. (I)

Limitations: May not carry enchantments.

Lives: 5



Scout

Anyone who survives for any time in the wilds learns the lay of the land. Many Native Americans are rightly seen as good trackers or Scouts, as were the mountain men who followed.

Examples: Strider, Hiawatha, Little John, Baden Powell

Garb: Green sash

Armor: 3 points

Shields: Small

Weapons: Dagger, short, long, staff, throwing weapons, short bows

Immunities: Immune to both magical and non-magical forms of *Lost*

Lives: 4

Abilities & Traits:

Levels

1st **Heal** (ex) (1/life)

2nd **Innate Ability** (choose one of the following):

a. **Stun Arrow** (1/reusable) (T)

b. **Flame Arrow** (1/reusable) (T)

3rd **Antidote to Poison** (ex) (1/life)

Truth (ex) (1/life)

Camouflage (ex) (1/game)

4th **Immunity:** Traps

Tracking (ex) (1/life)

5th **Earth Bind** (ex) (2/game)

6th **Tracking** becomes (2/life)

May now use a crossbow or longbow instead of a short bow (T)

Attuned (T) (2/game)

Warrior

Pure Warrior traditions also abound. Outstanding examples included the 300 Spartans who opposed the great Persian king Xerxes and his 10,000 Immortals, the incredibly warlike five nations of the Iroquois, and the fierce Maori clans native to New Zealand.

Examples: William Wallace, Lancelot, Achilles, Spartacus, Mad Mardigan, Miyamoto Musashi, Charles Martel, Roman Praetorians, and Julius Caesar

Garb: Purple sash

Armor: 4 points

Shields: Large

Weapons: All melee

Immunities: None

Lives: 5

Abilities & Traits:

Levels

1st No additional abilities

2nd May wear up to 6 points of armor (T)

Improve Weapon (ex) (1/game)

3rd Total lives increases to 6 (T)

May now use javelins (T)

4th **Improve Weapon** becomes (1/life)

Improve Shield (ex) (1/game)

5th **Repair Item** (ex) (1/life)

6th **Armor of Quality** (T)

Improve Shield becomes (2/game)

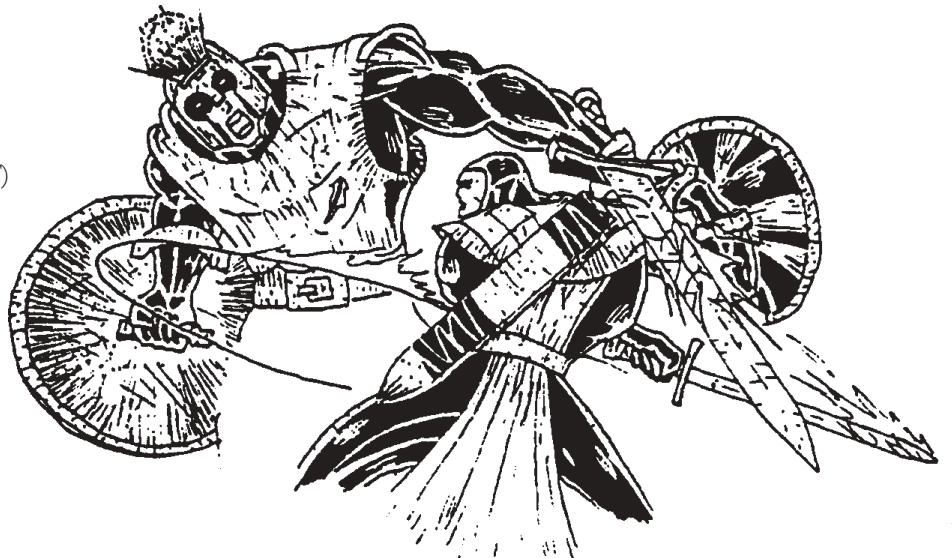

Wizard

The alchemists of the Dark Ages can be said to be Wizards, but 10,000-year old cave paintings in France indicate that the concept of fusing the spirit and physical worlds has been with us since the start.

Examples: Alannon, Gandalf, Morgana le Fey, Erasmus, Merlin, the Ithryn Luin

Garb: Yellow sash

Armor: None

Shield: None

Weapons: See the Magic section for a listing of weapons used. Weapons subtract from the Wizard's magic points.

Immunities: None

Lives: 4

Abilities & Traits:

Magic-user: Wizards are magic-users and gain magic at each level. See the Magic Section for more details.



Abilities and Traits Defined

Abilities Format Key:

- M: Materials needed
- I: Incantation and gestures
- R: Range (if any)
- E: Effect
- L: Limitations or Restrictions
- N: Notes

Accuracy

- E: Arrows fired from ones own bow or crossbow deal one additional point of damage.

Antidote to Poison

- M: A small container of water
- E: When a person drinks this water, they are instantly cured of any poison.

Armor-piercing Arrow

- M: A blue ribbon tied to an arrow
- I: Declare Loudly "Armor-piercing Arrow"
- E: A strike from the arrow will destroy all non-invulnerable armor on the location struck and will continue through to wound the target. It will only deal one point of damage to invulnerability and invulnerability armor.

Armor of Quality

- E: Any armor worn is worth one extra point to a maximum of seven points.
- N: This ability allows you to exceed your normal class maximum on armor by one point.

Assassinate

- I: Say the word 'Assassinate' immediately upon killing a person.
- E: The victim is affected as per the spell *Sever Spirit*.
- N: May be used while moving.

Attuned

- E: May choose to carry two enchantments from any caster (or combination of casters) for the duration of the current life.
- N: This ability may not be used in conjunction with any other similar ability or magic. Only one of these two enchantments may be simul-cast if both of them allow for it.

Awe

As per the *Awe/Fear* spell.

Banish

As per the *Banish* spell.

Berserk

M: A red headband or armband.

I: You may choose to go Berserk at any point on an eligible life by tying on the red band and announcing your Berserk state.

E: While Berserk you gain the following traits:

- a. **Natural armor:** 2 points on all hit locations.
- b. **Strong:** Melee weapons become Red. Melee weapons that are already Red do an extra point of damage to armor for a total of three.
- c. **Rage:** Weapons used while berserk must be over two feet in length. Players may not cast magic, use projectiles, shields, hinged weapons, or activate class abilities (except Berserk). Armor worn is considered destroyed, and cannot be used while berserk. You may not retreat from combat unless facing odds of at least 5:1, monsters with a ratio of 5:1 or greater, or a Wizard, Healer, Druid, or Bard.
- d. **Immunity:** Control

Bowyer

E: As per the *Mend* spell.

L: May only be used on a bow.

Camouflage

M: 10 ft green cloth

I: Place cloth in a circle, repeat x3 “May the forces of nature hide my presence.”
To end the camouflage, the player must repeat x2 “Nature release me.”

R: Within circle

E: While inside the circle, the player can't be attacked, even if someone viewed him activating the Camouflage. Area effect magic that encompasses the area of the camouflage, such as *Doomsday*, still affects the player. While camouflaged, the player may not affect anyone else, though they can use their own abilities on themselves such as healing or curing poison. The player may not camouflage anyone else (or their belongings), nor may game items be taken into camouflage. Any enemy with the **Tracking** ability within 20 feet can cancel the camouflage by stating “Tracking” and pointing out the player in question.

Earth Bind

I: Repeat x2 “May mother nature bind thee.”

R: 20 ft

E: Victim cannot move until each of his legs are struck ten times with a slashing or bludgeoning weapon. . Anyone attempting to free the victim must state “free this leg” while doing so or the hits strike the player as normal.

N: May be used while moving.

Extend Immunities

I: “My faith shall defend thee.”

R: Touch

E: Player extends all of his class immunities to one person with whom he is in direct physical contact. Immunities may not be extended to equipment. This ability ends as soon as physical contact is broken.

N: May be used while moving.



Dathin ©1994
of

Fight After Death

- E: Occurs immediately after having died. Player continues to fight for 10 seconds—which must be counted out loud—after dying. Limbs and armor lost before death remain lost, and additional limbs and armor can be removed, but this does not stop the berserker from continuing to function (save for losing the use of the limb) for the duration of the fight after death. Additional killing shots do not kill the barbarian. Fight After Death does not count as ‘moving after having died.’
- L: Being struck by a *Sphere of Annihilation* or a siege weapon will prevent or end Fight After Death.
- N: This ability does not free the player from any pre-existing effects such as *Stun* or *Earthbind*. As a reminder, a player is always required to stay in control of his actions. Violent flailing with real life disregard for others – during this or at any other time – is grounds for punishment or expulsion by the reeve. You can role-play a crazy person, but you must still have control of your actions at all times. Reeves are encouraged to remove this ability from those who are hurting or endangering others.



Flame Arrow

- M: An orange ribbon tied to the arrow
- I: Repeat x5 “flame arrow”
- E: A hit to a shield will destroy the shield unless its face is tapped to the ground five times within five seconds. A hit to a siege weapon by a flame arrow will do five points of damage to the siege weapon. Will deal damage to armor and people as normal. Has no effect on *Iceball*, *Entangle*, or any other magic unless specifically mentioned in the magic description. A flame arrow will remain lit for two minutes.

Heal

As per the *Heal* spell.

Improve Shield

- M: Purple ribbon visibly tied to shield
- E: Shield may only be destroyed by magical balls, Verbal magic, or siege weapons and is considered to be metal for game effect purposes.

Improve Weapon

- M: Purple ribbon tied to weapon
- E: Weapon deals +1 damage when wielded in a slashing or bludgeoning manner.
- N: Does not confer shield-breaking abilities.

Missile Block

- E: Player is allowed to block arrows with their weapons without penalty. If such a block is insufficient to prevent the projectile from striking the blocker, it still counts as a hit.

Missile Block, Greater

- E: Functions exactly like Missile Block except it also allows the player to use bare hands to block projectiles and arrows without penalty.

Pass Without Trace

- I: Repeat x3 “Pass without trace”
- E: You must immediately return to your base. You are considered out of the game while returning.
- N: May be used while moving.

Penetration Arrow

- M: Denote arrow with black ribbon
- E: Behaves exactly like an **Armor-piercing Arrow** except that it will also destroy a normal shield. It will not carry through to the arm underneath, however.

Poison Weapon

M: Denoted with black ribbon

E: May poison one edged weapon. People who are wounded by poisoned weapons die if they are not cured in a 100 count. A person may only poison one of his own edged weapons. This effect remains on the weapon for the entire life.

Powerful Blows

I: Announce “Powerful Blows” before engaging in combat

E: Your weapons are treated as magical for the purposes of damaging monsters that are only affected by magic weapons.

Repair Item

E: As per the *Mend* spell.

L: May only be used on one’s own equipment.

Resurrect

As per the *Resurrect* spell.

Sanctuary

I: Drop weapons if any in hand and state “Sanctuary”

R: 20 ft radius from the player

E: Others within 20’ may not take hostile actions towards the player, nor target the player or his equipment with magic or abilities.

L: Must be chanting “Sanctuary” and cannot be holding a weapon or the ability is broken. Cannot carry nor affect game items while in Sanctuary. Players in Sanctuary may not impede the play of other people in any manner, and must immediately remove themselves from any such situations they find themselves in.

N: The *Touch of Death* and *Touch of Paralyzation* abilities and magic are not considered weapons in Sanctuary. If these are on the player when he enters Sanctuary, they can be discharged as normal, though this ends the Sanctuary. The player may move around during Sanctuary, but they must keep at least one foot on the ground at all times and may not run. Sanctuary is broken if the monk comes within 20 feet of a base.



Steal Life

S: Death

M: Dead person

I: Touch target on their shoulder and recite “I take your life”

R: Touch

E: Target loses one life from their total and the user gains one life. This life is in addition to the person already being dead. You cannot steal lives from those already shattered.

N: This effect may be used on any dead person who has not yet reached nirvana, even if they have moved from where they died. May be used while moving.

Stun Arrow

M: Denote arrow with gray ribbon.

E: Arrow behaves as a Subdual blow.

Teleport

As per the *Teleport* spell except may be only used on self.

Touch of Death

As per the *Touch of Death* enchantment except may only be placed on self.

Tracking

I: Repeat x5 “Tracking”

R: Self

E: You may do ONE of the following:

- a. You may ask one yes or no question of someone (dead person, reeve or monster) that must be answered truthfully and to the best of their ability. This is not stopped by the *Liplock* magic
- b. Follow a teleporting player
- c. Walk through a *Thornwall*
- d. “Dispel” a camouflage or blend ability

Trap

I: Repeat x2 “The upturned points of my caltrops render you lame.”

R: 20 feet

E: Target may not move at more than a slow walk for a 50 count.

N: This is not a wound. May be used while moving.

Transfer Life

S: Spirit

M: Person

I: Touch person and state “I give thee life from my own.”

R: Touch

E: This ability has two possible effects:

1. A dead person is immediately resurrected as per the spell *Resurrect*.
2. A living person gains one extra life on their current life total.

In addition, the monk loses one life from his total. If he was on his last life when he used this ability, he dies immediately and may not be restored to life.

L: You may only use this ability on a person playing a standard class. Lives given to people playing transformed monsters are played as the original class, not the monster.

Truth

As per the *Truth* spell.

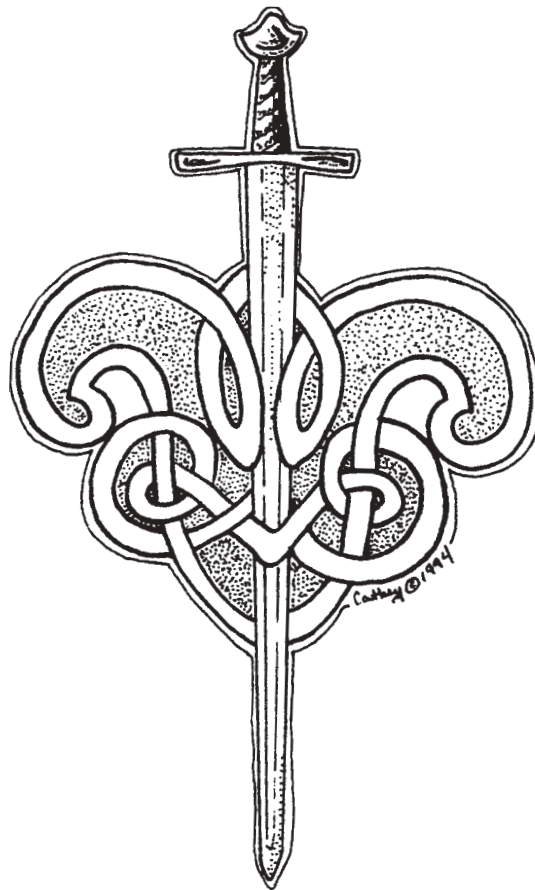

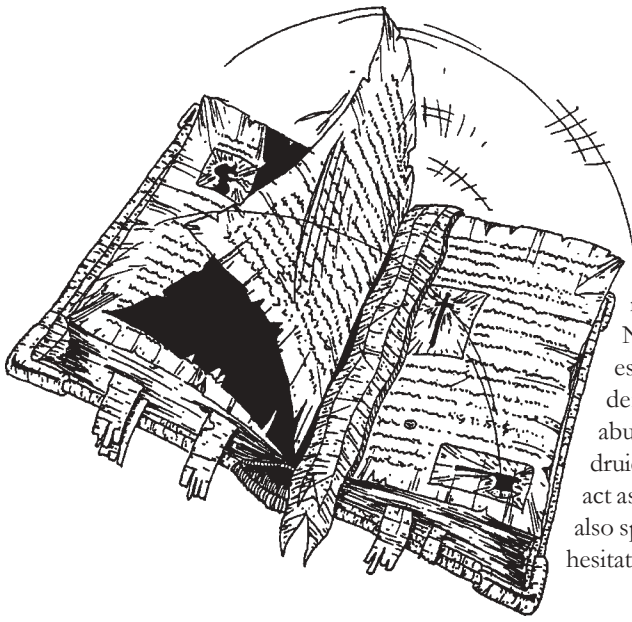

Amtgard Magic

Amtgard's magic system is one of its most unique qualities. Playing a magic user requires the participant to think and is a constant challenge. Note that a delicate balance exists between all the classes. Each class, especially those with magic, must be played within the spirit of the rules defining it. There is a great deal of trust and honor involved, and someone abusing the rules of any class can easily disturb game balance. Wizards, healers, druids and bards (collectively referred to as magic-users) are urged to dress and act as recognizable members of their classes, which are not only powerful, but also spectacular. If you have difficulty understanding the magic system, don't hesitate to ask your Guildmaster or a Reeve. Happy magic casting!

The Rules of Magic

- 1) Magic must be said loudly and clearly enough to be heard within 50 feet or by the recipient, whichever is closer.
- 2) When casting verbal magic with a single target, the caster must announce the target's name immediately before the incantation (class and a unique descriptor will suffice if name is unknown).
- 3) A player may not move their feet when casting magic, unless otherwise stated or specified in the magic's description. The same applies to all class abilities and skills that require activation. If a player moves his feet while casting magic it is interrupted and not cast. The caster must reset and begin casting again.
- 4) The target of magic must be in range at the time the spell is completed in order for it to count.
- 5) Incomplete or interrupted magic has no effect, and does not count as if it were used.
- 6) Any hand being used to cast magic must be empty with the exception of magical components or the target of a touch spell such as *Heal*. Magical balls charged in the left hand may be transferred to the right hand before throwing.
- 7) Unless they buy *Ambidexterity* Wizards and Druids must cast magic with their left hand, and may not cast if their left arm is wounded. Healers and Bards may cast with either hand.
- 8) All magic is listed as a spell, enchantment, fixed enchantment, magical ball or neutral. This distinction can have a great impact on play so note it carefully. Unless noted otherwise, fixed enchantments follow all general rules for enchantments. Unless noted otherwise, magical balls follow all general rules for spells.
- 9) Enchantments (E)
 - a. A person may carry only one at a time unless explicitly noted otherwise in a spell or class, such as the *Stack* magic or the **Attuned** ability. Note: *Reanimate* and *Lich* are enchantments.
 - b. When a person moves from where they died, any enchantments they carry are lost. Unless they have moved, *Resurrected* players retain enchantments unless specifically prohibited. *Summon Dead* does not return missing enchantments to players.
 - c. Will only cover one object (for example a person, a weapon, armor, etc). Thus while you may be protected from flame, your armor and equipment is not. The same applies to class abilities.
 - d. Enchantments cast on equipment count against the number of enchantments that may be carried.
 - e. Enchantments cast on equipment only function when used by the player who was in possession of the item when it was enchanted. Example: If you give a *Bladesharped* sword to another player, the enchantment does not function.
 - f. If you are carrying an enchantment you cast, it is removed when you begin casting other magic unless otherwise noted.
 - g. May not be cast on unwilling participants or their equipment; though this does not prevent them from being the target of enchantment effects such as *Touch of Death*.
 - h. Must be denoted by a visible enchantment strip and announced if asked.
 - i. Enchantments nullified must be removed. Enchantments on a dead player should remain while on the battlefield as they may affect attempts to *Resurrect*, *Talk to Dead*, etc.
 - j. If already wearing your maximum number of enchantments, you must have an enchantment removed by the appropriate means (*Cancel* from the caster, *Dispel Magic*, etc) before receiving another one.
 - k. When cast upon objects, they cover the entire object; i.e. A robe with *Protection from Flame* on it would prevent *Fireballs* from affecting the wearer if they struck the robe. If they struck a part of the player not covered by the robe then the player would be affected as normal.
 - l. May be dispelled.

- 10) Fixed Enchantments (FE)
 - a. Disappear (never to return) when their caster dies or travels farther than 100 feet from them.
 - b. Are considered to be on the area of ground and do not dissipate when other magic is cast.
 - c. A player may only have a single fixed enchantment active at a time. Casting a fixed enchantment while another fixed enchantment from the same player is already active causes both enchantments to be negated.
 - d. May be dispelled.
- 11) Magical Balls (B)
 - a. A magic-user may physically carry no more than 12 magical balls, total. Pages and other players may not carry extra magical balls for magic-users.
 - b. A magic-user may have only one type of magical ball charged at a time. "Remain Active" *Fireballs* do not count for this purpose.
 - c. When an item is struck by multiple simul-cast magical balls, only the first magical ball from that group affects that item; i.e. A shield hit by two simul-cast *Lightning Bolts* is simply destroyed, but the wielder is unharmed. This rule does not apply to armor; i.e. If a player wearing torso armor and two *Protects* is struck in the torso armor by two simul-cast *Ice Balls*, he loses both of his *protects*.
 - d. When a *Lightning Bolt*, *Fireball*, or similar destructive magical ball strikes a player in a location covered by armor, the armor is destroyed in that hit location and the magic affects the player as normal unless otherwise noted. Magical balls that deal damage (such as *Magic Bolt*) affect armor as normal per projectiles unless otherwise noted.
 - e. Magical balls of the Subdual School have no effect on equipment that is not being carried. Example: You may not *Iceball* a player's shield if it is not being wielded or carried by them.
 - f. Magic balls, except where explicitly noted, only affect the first thing they hit.
 - g. Unless otherwise noted, magical balls are not engulfing.
 - h. Barring any enchantments or magical effects, garb strikes count as hitting the player if the magic ball would have continued on to hit the player. I.e. You may not block *Lightning Bolts* with your cloak.
- 12) All magic classes must have a list of which magic they have bought for that game on them at all times. Failure to have this list renders a player incapable of casting magic. Bards require a musical instrument (your voice is not sufficient, nor is a blade of grass, piece of straw etc.) Along with a spell list. Failure to wear appropriate class garb also negates the ability to use magic.
- 13) Beginning an incantation discharges all of your unused magical balls and interrupts the incantation of any other magic you were casting.
- 14) Magic points must be evenly distributed between levels; however, any number of higher level magic points may be deducted from a higher level to be spent on a lower level once the initial distribution is done. Certain neutrals allow purchasing multiple points worth of lower level magic. In all such cases these lower level points must be purchased prior to the start of the battlegame and indicated on the list of magic bought.
- 15) Relics such as the **Sword of Flame** are objects of great power. A relic will generally win any question of magical superiority unless the magic specifically states otherwise. For example, *Sphere of Annihilation* does not destroy the **Shield of Reflection**.
- 16) Spells completely cast and enchantments discharged are considered used, even if they were ineffective against their targets. The same is true of all class abilities. Example, a Warrior bearing the *Touch of Death* enchantment attempts to use it on a 6th level monk. The Monk is immune to the effect and the enchantment is discharged.
- 17) In the event of a conflict between magic that is not directly covered by the rules, the higher-level magic is considered more powerful. If the magic is of the same level, the defensive magic is more powerful.
- 18) In the case of confusion or contradictions, then the specific magic description should be the final source. Use your common sense when ironing out problems.
- 19) The Reeve's word is final. If what looks like 30 ft. To you is determined to be 60 ft. By a reeve, then it is 60 ft.
- 20) Protections cast on a target have no effect on effects already active; i.e. Casting *Protection from Magic* on a person who is *Yielded* does not free them from the *Yield*, though it would prevent them from being killed by a *Fireball*.

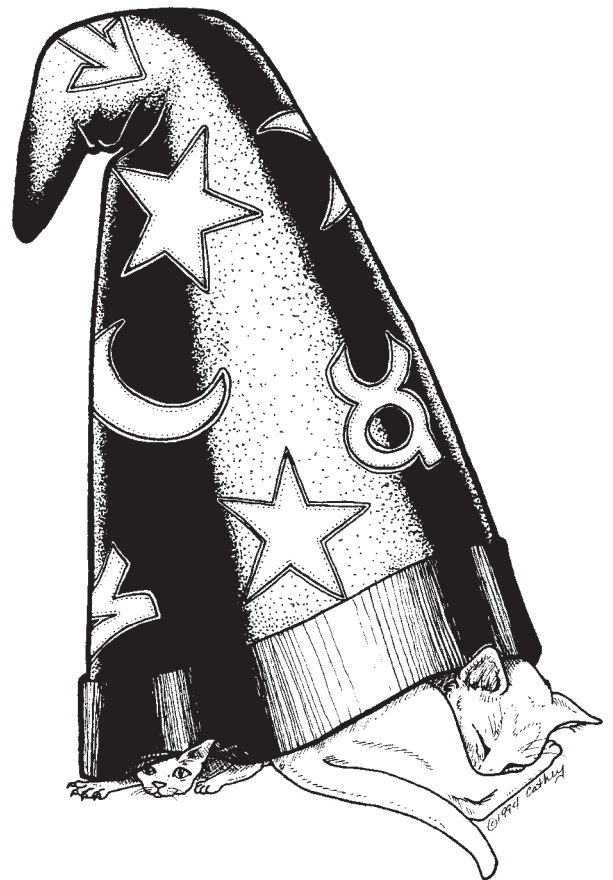

Magic Clarifications

- 1) Immunities to magic are based on the School of magic they belong to. Exceptions to this are noted under the limitations of the spell. Note that immunities do not extend to equipment.
- 2) Additional immunities, unless specified, do not exist.
- 3) Reeves may assist in placing a magic-user's components, such as markers for a fixed enchantment.
- 4) A break in the casting of magic is defined as either improper or non-magical wording and/or a gap of two or more seconds between words. This prevents, for example long spells from being cast while under the influence of a magic that requires an ongoing verbal component such as the chanting of "Commune" for the *Commune* spell. Effects and magic with ongoing chants require the chant to be repeated with no more than a 5 second gap between iterations. These chants must be audible to 50 feet.

Magic Relics

Certain items of power are used in the battlegames and are passed on to new owners every six months via a Quest. Each Amtgard group may use its own Relics, though these are not to be used in regional or national battlegames. The effects and abilities of Relics are considered to be non-magical in nature; hits from Relics are considered magical. Relics include:

Dagger of Infinite Penetration

When thrown destroys all non-invulnerable armor on the hit location struck and continues through to hit the target. Counts as one hit against invulnerability and invulnerability armor. If it strikes a shield the shield is destroyed without affecting the wielder.

Homestone

Allows the holder to *Mend* broken weapons and shields (I: "I mend this item" x 10). It also allows the person's dead teammates to come back alive at his location rather than having to return to their base.

Heimdall's Horn

A one handed 'red' weapon only usable by barbarians, and in fact, the only relic allowed to barbarians.

Ring of Power

Negates the first hit from each separate opponent per battlegame. Counts against weapons and any enchantments only, it is ineffective against spells and magic balls. Does work against class abilities.

Shield of Reflection

Is completely indestructible. Will negate any effect that strikes it, even siege weapons and magic. Any magic ball of the Subdual school striking the Shield of Reflection instead affects the caster.

Sword of Flame

Is considered flame (as per *Flameblade*) and will kill a victim if it strikes any legal unprotected area (as per *Imbue Weapon*). Confers upon itself and its owner *Protection from Flame*. May only be used by one person, for one life, per game.

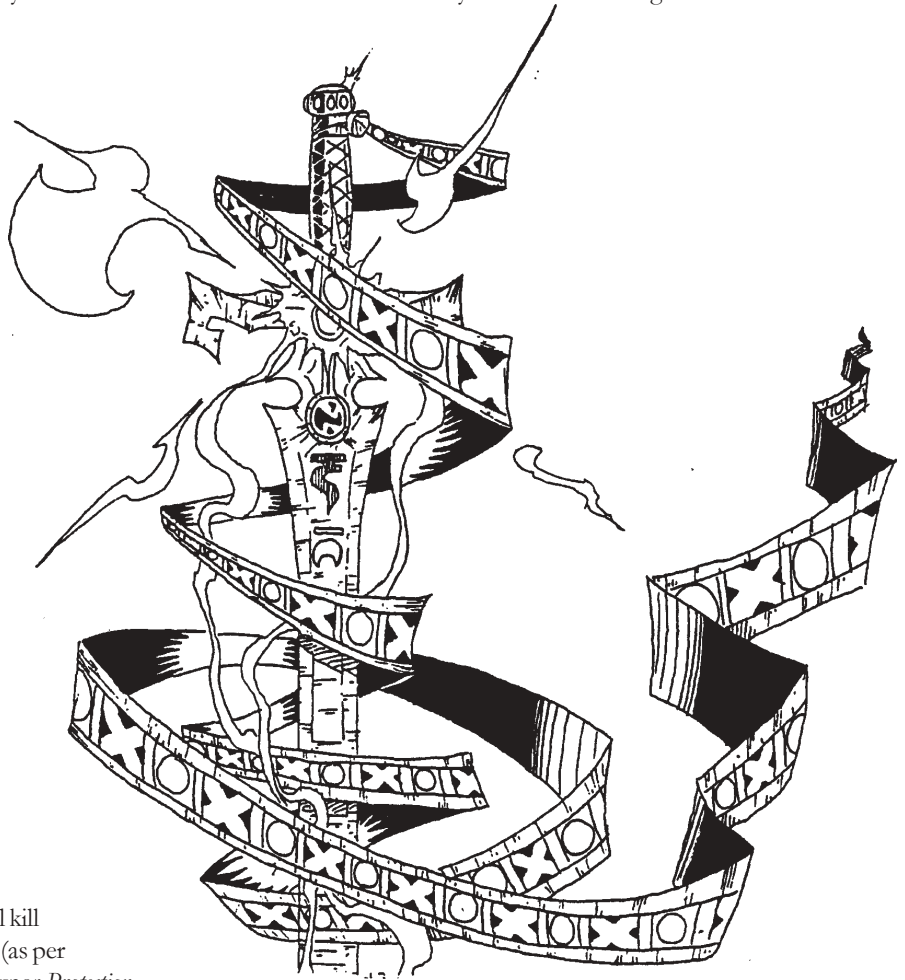

The Schools of Magic:

There are eight schools of magic. Each represents a different type of effect.

Please note that immunities are based on what school a magic is in. Therefore, as *Hold Person* is a magic of the **Subdual** school, a barbarian, immune to subdual effects, is not affected. *Stun*, on the other hand, is of the **Sorcery** school, and barbarians would be affected by it.

- Control:** controls the mind, will, or senses of the target.
- Death:** an effect whose consequence is death or the withering of a body part.
- Flame:** produces heat, fire, or lightning.
- Neutral:** magic that is neutral in terms of its School. They cannot be dispelled.
- Protection:** causes the target to be protected in some way.
- Sorcery:** effects that are purely magical in nature or somehow affect magic itself.
- Spirit:** an effect that has to do with the forces of life. Includes healing.
- Subdual:** causes the target to be subdued in some manner.

Sorcery Magic

Acid Bolt
Anti-Magic
Berserk
Bladesharp/Bludgeon
Cancel
Circle of Protection
Commune
Confidence
Dispel Magic
Imbue Weapon
Flight
Forcewall
Honor Duel
Liplock
Magic Bolt
Magical Projectile
Mend
Messenger
Plant Door
Release
Shove
Silence
Sphere of Annihilation
Stun
Teleport
Thornwall
Touch of Death
Touch of Paralyzation
Transform
Warp Wood
Wind

Subdual Magic

Entangle
Hold Person
Iceball
Lost
Mass Sleep
Petrify
Sleep
Stun Weapon
Touch of Paralyzation

Spirit Magic

Banish
Cure Disease
Cure Poison
Heal
Heal Extend
Lich
Reanimate
Regeneration
Reincarnate
Resurrect
Sever Spirit
Summon Dead
Swords to Plowshares
Talk to Dead

Flame Magic

Call Lightning
Fireball
Flameblade
Flamewall
Immolation
Heat Weapon
Lightning Bolt
Pyrotechnics

Protection Magic

Barkskin
Bless
Defend
Imbue Shield
Harden
Protect
Protection from Control
Protection from Death
Protection from Disease
Protection from Flame
Protection from Magic
Protection from Projectiles
Protection from Subdual
Stoneskin

Control Magic

Awe/Fear
Charm
Confusion
Feeblemind
Legend
Lore
Mute
Truth
Yield

Death Magic

Doomsday
Finger of Death
Killing Grounds
Mutual Destruction
Touch of Death
Wounding

Neutral Magic

Advancement
Ambidexterity
Dance
Enhancement
Expertise
Extension
Imbue
Lend
Mimic
Presence
Stack
Visit
Vivify
Voice
Warskill



Magic Listing Key:

Type – enchantment (E), fixed enchantment (FE), spell (S), magical ball (B), neutral (N)

Uses – number of times you may cast that magic when you pay for one use. (“u” means unlimited)

Cost – the number of magic points it costs to buy one use of that magic.

Max – the maximum number of uses of that magic that you may purchase.

School – The School of magic the magic belongs to.

Magic Format Key:

Magic Name (Abbr. for Type, School)

C: Classes who can use the magic, and the level needed to cast them.

I: Incantation and gestures

R: Range (if any)

E: Effect

L: Limitations or Restrictions

N: Notes

Magic Points:

Magic points usable to buy magic at that level

Level	1 st	2 nd	3 rd	4 th	5 th	6 th
1	10					
2	10	10				
3	10	10	10			
4	7	8	7	8		
5	6	6	6	6	6	
6	5	5	5	5	5	5

Weapon Costs for Magic-Users (from available magic points):

Cost per 10 points of magic (multiple weapons must be paid for, even if of the same type)

Weapon	Bard	Druid	Healer	Wizard
Dagger	0	0	0	0
Short (3 ft)	3	2	3	2
Long (4 ft)	4	4	5	4
Spear	-	4	-	3
Staff	2	2	3	2
Hinged	-	-	3	-
Shield	3	4	3	-
Bow, Short	-	5	-	-



Weapon to Magic Point Cost per Level (from available magic points)

This table lists how many points you have left after deducting a weapon's cost from your magic points. In the case of multiple weapons, add their costs together and use the chart for their combined cost. For magic-user's level's 1-3, simply deduct the total weapon cost from each level of magic. For example a two point weapon would allow a player eight points of first, eight points of second, and eight points of third level magic. Note: You may carry any number of 'backup' weapons, but may only use the number you have paid for. Example: A player who bought a short sword may carry more than a single short sword, but he may not fight Florentine unless he paid the points for another short sword.

Quick Reference of Deductions for Weapons Based on Cost

Weapon Cost	Magic User's Level	1 st	2 nd	3 rd	4 th	5 th	6 th
1	4	6	7	7	7		
	5	5	5	6	5	6	
	6	4	5	4	5	4	5
2	4	6	6	6	6		
	5	4	5	5	5	5	
	6	4	4	4	4	4	4
3	4	5	5	5	6		
	5	4	4	4	4	5	
	6	3	4	3	4	3	4
4	4	4	5	4	5		
	5	4	3	4	3	4	
	6	3	3	3	3	3	3
5	4	3	4	4	4		
	5	3	3	3	3	3	
	6	2	3	2	3	2	3
6	4	3	3	3	3		
	5	2	2	3	2	3	
	6	2	2	2	2	2	2
7	4	2	2	2	3		
	5	1	2	2	2	2	
	6	1	2	1	2	1	2
8	4	1	2	1	2		
	5	1	1	1	1	2	
	6	1	1	1	1	1	1
9	4	0	1	1	1		
	5	1	0	1	0	1	
	6	0	1	0	1	0	1



Magic per Class and Level

The following tables list the magic available to magic-users at their respective levels. The table lists the magic's name, its type, School, number of uses, cost and max number that may be purchased.

Bard Magic

First Level

Magic name	Type	School	Uses	Cost/Max	Range
Cancel	S	Sorcery	Unlimited	0/-	50'
Charm	S	Control	1/life	2/2	20'
Hold Person	S	Subdual	1/life	2/2	20'
Presence	N	Neutral	1/game	1/4	—
Protection from Control	E	Protection	1/game	1/4	T
Visit	N	Neutral	1/game	1/4	—

Second Level

Magic name	Type	School	Uses	Cost/Max	Range
Legend	S	Control	1/game	1/4	20'
Liplock	E	Sorcery	Unlimited	2/-	T
Protection from Subdual	E	Protection	1/game	1/4	T
Talk to Dead	S	Spirit	1/life	1/-	T
Truth	S	Control	1/life	2/2	20'

Third Level

Magic name	Type	School	Uses	Cost/Max	Range
Extension	N	Neutral	1/life	1/2	—
Imbue	N	Neutral	1/game	1/2	—
Confidence	E	Sorcery	1/game	1/2	T
Sleep	S	Subdual	1/life	2/4	20'

Fourth Level

Magic name	Type	School	Uses	Cost/Max	Range
Awe/Fear	S	Control	1/game	1/4	20'
Berserk	E	Sorcery	1/game	1/2	T
Honor Duel	S	Sorcery	Unlimited	1/-	20'
Lore	S	Control	1/life	2/2	20'
Warskill	N	Neutral	1/game	2/1	—

Fifth Level

Magic name	Type	School	Uses	Cost/Max	Range
Confusion	S	Control	1/game	1/2	50'
Mimic	N	Neutral	1/game	2/1	—
Mute	S	Control	1/life	2/4	20'
Yield	S	Control	1/game	2/4	50'

Sixth Level

Magic name	Type	School	Uses	Cost/Max	Range
Dance	N	Neutral	1/game	2/2	—
Release	S	Sorcery	1/life	1/4	20'
Voice	N	Neutral	1/game	2/1	—

Druid Magic

First Level

Magic name	Type	School	Uses	Cost/Max	Range
Cancel	S	Sorcery	Unlimited	0/-	50'
Cure Poison	E/S	Spirit	1/life	1/4	T
Entangle	B	Subdual	1 bolt/U	1/2	—
Heal	S	Spirit	1/life	1/4	T
Heat Weapon	S	Flame	1/life	1/4	20'
Bladesharp/Bludgeon	E	Sorcery	1/game	1/4	T
Warp Wood	S	Sorcery	1/life	1/4	20'

Second Level

Magic name	Type	School	Uses	Cost/Max	Range
Barkskin	E	Protection	1/game	1/4	T
Cure Disease	S	Spirit	1/life	1/4	T
Magical Projectile	E	Sorcery	1/game	1/4	T
Mend	S	Sorcery	1/life	1/8	T
Touch of Paralyzation	E	Sorcery/Subdual	1/game	1/4	T
Thornwall	FE	Sorcery	1/game	1/4	T

Third Level

Magic name	Type	School	Uses	Cost/Max	Range
Acid Bolt	B	Sorcery	1 bolt/U	1/2	—
Ambidexterity	N	Neutral	Unlimited	2/-	—
Confusion	S	Control	1/game	1/2	50'
Extension	N	Neutral	1/life	1/2	—
Plant Door	S	Sorcery	1/game	1/4	T
Protection from Disease	E	Protection	1/game	1/4	T
Protection from Flame	E	Protection	1/game	1/4	T

Fourth Level

Magic name	Type	School	Uses	Cost/Max	Range
Call Lightning	S	Flame	1/game	2/4	20'
Commune	S	Sorcery	Unlimited	2/-	Self
Flamewall	FE	Flame	1/game	1/4	T
Silence	FE	Sorcery	1/game	1/4	T
Pyrotechnics	S	Flame	1/game	1/4	50'
Stoneskin	E	Protection	1/game	2/2	T

Fifth Level

Magic name	Type	School	Uses	Cost/Max	Range
Flameblade	E	Flame	1/game	1/2	T
Teleport	S	Sorcery	1/game	1/4	T
Petrify	B	Subdual	1 bolt/U	2/2	—
Release	S	Sorcery	1/life	1/4	20'
Regeneration	E	Spirit	1/game	1/2	T

Sixth Level

Magic name	Type	School	Uses	Cost/Max	Range
Finger of Death	S	Death	1/game	2/2	50'
Feeblemind	S	Control	1/game	2/2	50'
Immolation	FE	Flame	1/game	1/4	T
Reincarnate	E	Spirit	1/game	2/2	T

Healer Magic

First Level

Magic name	Type	School	Uses	Cost/Max	Range
Cancel	S	Sorcery	Unlimited	0/-	50'
Cure Poison	E/S	Spirit	1/life	1/4	T
Heal	S	Spirit	Unlimited	0/-	T
Lost	S	Subdual	1/game	1/4	20'
Mend	S	Sorcery	1/life	1/8	T
Mute	S	Control	1/life	2/4	20'
Talk to Dead	S	Spirit	1/game	1/-	T

Second Level

Magic name	Type	School	Uses	Cost/Max	Range
Banish	S	Sorcery	1/life	1/4	20'
Bless	E	Protection	1/life	2/4	T
Cure Disease	S	Spirit	1/life	2/4	T
Swords to Plowshares	S	Spirit	1/life	1/2	20'
Entangle	B	Subdual	1 bolt/U	1/2	—
Heal Extend	S	Spirit	1/life	1/-	20'
Sleep	S	Subdual	1/life	2/4	20'

Third Level

Magic name	Type	School	Uses	Cost/Max	Range
Mass Sleep	S	Subdual	1/game	1/1	LOS
Protect	E	Protection	1/game	1/4	T
Protection from Disease	E	Protection	1/game	1/4	T
Resurrect	S	Spirit	1/game	1/8	T
Stun	S	Sorcery	1/game	1/4	20'
Wounding	S	Death	1/life	1/2	20'
Yield	S	Control	1/game	2/4	50'

Fourth Level

Magic name	Type	School	Uses	Cost/Max	Range
Enhancement	N	Neutral	1/game	1/1	—
Harden	E	Protection	1/game	1/4	T
Release	S	Sorcery	1/life	1/4	20'
Sever Spirit	S	Spirit	1/life	2/4	T
Touch of Death	E	Sorcery/Death	1/game	1/4	T

Fifth Level

Magic name	Type	School	Uses	Cost/Max	Range
Awe/Fear	S	Control	1/game	1/4	20'
Extension	N	Neutral	1/life	1/2	—
Protection from Death	E	Protection	1/game	1/4	T
Summon Dead	S	Spirit	1/life	1/-	50'

Sixth Level

Magic name	Type	School	Uses	Cost/Max	Range
Circle of Protection	FE	Sorcery	Unlimited	2/-	T
Dispel Magic	S	Sorcery	1/game	1/4	20'
Protection from Magic	E	Protection	1/game	1/4	T
Teleport	S	Sorcery	1/game	1/4	T

Wizard Magic

First Level

Magic name	Type	School	Uses	Cost/Max	Range
Bladesharp/Bludgeon	E	Sorcery	1/game	1/4	T
Cancel	S	Sorcery	Unlimited	0/-	50'
Imbue Shield	E	Protection	1/game	1/4	T
Heat Weapon	S	Flame	1/life	1/4	20'
Honor Duel	S	Sorcery	Unlimited	1/-	20'
Iceball	B	Subdual	1 bolt/U	1/2	—
Magic Bolt	B	Sorcery	1 bolt/U	1/4	—
Shove	S	Sorcery	1/life	1/4	20'
Stun Weapon	E	Subdual	Unlimited	0/-	T
Talk to Dead	S	Spirit	1/game	1/-	T

Second Level

Magic name	Type	School	Uses	Cost/Max	Range
Circle of Protection	FE	Sorcery	Unlimited	2/-	T
Forcewall	FE	Sorcery	1/game	1/4	T
Harden	E	Protection	1/game	1/4	T
Hold Person	S	Subdual	1/life	1/4	20'
Lightning Bolt	B	Flame	1 bolt/U	1/4	—
Liplock	E	Sorcery	Unlimited	2/-	T
Mend	S	Sorcery	1/life	1/4	T
Messenger	E	Sorcery	1/game	1/-	T
Protection from Flame	E	Protection	1/game	1/4	T
Wounding	S	Death	1/life	2/2	20'

Third Level

Magic name	Type	School	Uses	Cost/Max	Range
Ambidexterity	N	Neutral	Unlimited	2/-	—
Anti-Magic	FE	Sorcery	1/game	1/2	T
Dispel Magic	S	Sorcery	1/game	1/4	20'
Extension	N	Neutral	1/life	1/2	—
Mutual Destruction	S	Death	1/game	1/4	50'
Protection from Projectiles	E	Protection	1/game	1/4	T
Protect	E	Protection	1/game	1/2	T
Touch of Death	E	Sorcery/Death	1/game	1/4	T
Wind	S	Sorcery	1/game	2/2	LOS
Yield	S	Control	1/game	1/2	50'

Fourth Level

Magic name	Type	School	Uses	Cost/Max	Range
Doomsday	S	Death	1/game	2/1	LOS
Imbue Weapon	E	Sorcery	1/game	1/4	T
Finger of Death	S	Death	1/game	2/2	50'
Fireball	B	Flame	1 bolt/U	2/2	—
Protection from Magic	E	Protection	1/game	1/4	T
Pyrotechnics	S	Flame	1/game	1/4	50'
Sever Spirit	S	Spirit	1/life	2/4	T
Teleport	S	Sorcery	1/game	1/4	T

Fifth Level

Magic name	Type	School	Uses	Cost/Max	Range
Advancement	N	Neutral	1/game	1/1	—
Flight	E	Sorcery	1/game	2/4	Self
Lend	N	Neutral	1/game	1/4	—
Lich	E	Spirit	1/game	1/2	Self
Reanimate	E	Spirit	1/life	2/2	T
Vivify	N	Neutral	1/game	2/1	—

Sixth Level

Magic name	Type	School	Uses	Cost/Max	Range
Defend	E	Protection	1/game	2/1	Self
Expertise	N	Neutral	1/game	2/1	—
Killing Grounds	FE	Death	1/game	2/1	T
Sphere of Annihilation	B	Sorcery	1 bolt/U	2/1	—
Stack	N	Neutral	1/game	1/4	—
Transform	E	Sorcery	1/game	2/1	—

T

Magic Descriptions

Acid Bolt (B, Sorcery)

C: Druid 3

M: Padded green “acid” ball with streamers

I: Hold ball and repeat x5 “Acid Bolt”

E: This ball of acid is considered to be a Red throwing weapon. Will wound/kill as normal on limb/torso shots. Deals two points of damage to armor and will destroy a normal shield in three blows, but may be parried by a weapon without penalty.

N: It is not stopped by *Protection from Projectiles*. (**Greater**) *Missile Block* is ineffective against this.

Advancement (N, Neutral)

C: Wizard 5

E: May purchase up to three points worth of first level magic.

Ambidexterity (N, Neutral)

C: Druid 3, Wizard 3

E: User may cast magic with either hand.

Anti-Magic (FE, Sorcery)

C: Wizard 3

M: 50 ft. Measure, yellow markers

I: Mark an area with a 50 ft. Radius, repeat x20 “May all forms of magic forsake this place.”

E: No magic of any kind will work within the circle, though enchantments will reappear when removed from the affected area.

N: *Dispel Magic*, if cast from outside the sphere of influence, will remove *Anti-Magic*.

Awe/Fear (S, Control)

C: Bard 4, Healer 5

I: For *Awe* repeat x3 “I make thee in awe” or for *Fear* repeat x3 “I make thee afraid.”

R: 20 ft.

E: Target may not attack or cast magic at the caster and must remain at least 20 ft away from the caster at all times for a 300 count.

L: If the caster attacks or casts another magic at the target, this spell’s effect is negated.

N: Victims may still cast area-effect magic (like *Doomsday*) that would affect the caster but do not specifically target him.



Banish (S, Spirit)

- C: Healer 2
- M: Undead or extra-planar creature.
- I: Repeat x5 “I banish thee monster.”
- R: 20 ft.
- E: Monster is removed from play for a 300 count. It will come back at the spot where it was *Banished*—does not count as a life lost for the creature. Three successful *Banishments* on the same life of a creature will kill the creature.
- N: May not be dispelled. Only usable on undead and extra-planar creatures.

Barkskin (E, Protection)

- C: Druid 2
- M: Person, enchantment cloth
- I: Touch person and repeat x5 “May nature protect thee,” attach cloth to person.
- E: Recipient gains one point of armor to all hit locations.
- L: The protection is only from physical attacks. Cannot be used with other armor.
- N: May be simul-cast up to two times for a total of two points of armor. Behaves just like normal armor. May be cast on players that cannot normally wear armor. Is not a form of invulnerability.

Berserk (E, Sorcery)

- C: Bard 4
- M: Enchantment cloth, Red Head Band.
- I: Touch target, repeat x2
 “The anger builds within thy veins
 No longer shall thou keep it caged
 Thine enemies shall feel the pain
 Thy Crimson visaged berserk rage!”
 Place cloth and red headband clearly visible on target.
- E: Player gains all the abilities and restrictions listed for the **Berserk** ability for the duration of the life enchanted. May not return to “normal” until the enchantment is removed by magic or death.
- L: Player does not gain **Fight After Death** unless they may normally do so while berserk (3rd level or higher barbarians). May not be used on players who are already berserk.
- N: This is the only enchantment that can be cast on barbarians. Each player can have this cast on them only once each game.

Bladesharp/Bludgeon (E, Sorcery)

- C: Wizard 1, Druid 1
- M: Enchantment cloth
- I: Hold weapon in free hand and repeat x10 “Improve this weapon,” tie cloth on weapon.
- E: Weapon deals one additional point of damage when slashing. May be simul-cast up to four times on one weapon allowing it to deal up to four extra points of damage. This does not make it a red weapon.
- L: Only usable on bladed or blunt weapons; cannot be applied to piercing or projectile weapons.

Bless (E, Protection)

- C: Healer 2
- M: Enchantment cloth, item of garb or armor
- I: Touch item and repeat x5 “I bless thee,” tie cloth to item.
- E: Person is immune to the first physical hit of any type, excluding magical balls.
- L: Immunity only applies to areas covered by the item. May not be simul-cast.
- N: Is not armor, may not be *Mended* or *Healed*. Is considered a form of limited invulnerability.

Call Lightning (S, Flame)

- C: Druid 4
- I: Raise empty hands above head and repeat x3 “I call lightning to strike thee.”
- R: 20 ft.
- E: Target is dead.

Cancel (S, Sorcery)

- C: Bard 1, Druid 1, Healer 1, Wizard 1
- I: Repeat x2 “I cancel my magic.”
- R: 50 ft
- E: A spell, enchantment, or fixed enchantment you cast is negated and expended
- L: May not be used on a magical ball already thrown. Magic that is completed when cast such as *Heal* and *Resurrect* cannot be cancelled.

Charm (S, Control)

C: Bard 1

I: State “Charm” – followed by a 20 syllable or more poem – followed by “Charmed.”

R: 20 ft

E: Enemy player is given a task by the caster, such as sing or dance about, which he must perform. The caster should describe what he wants the *Charmed* player to do within a 50 count after casting the spell. The caster may not be attacked by the victim during this time. If the caster dies before the instructions for the *Charm* are given, the player is freed of the *Charm*. If the caster has not given his instructions within a 50 count the *Charmed* player is freed. Spell ends when the task is completed or a 150 count has elapsed, whichever comes first.

L: You may not *Charm* somebody to affect his own person, equipment, or teammates. The victim may defend himself if attacked, but otherwise may not interact with other players unless it is required to complete the *Charm*. The victim may move immediately to a safe, out of the way location, if performing the *Charm* at their current location would place him at a battlefield disadvantage. If moving to a safe location, the count for the *Charm* begins when the victim arrives at that location. Impossible tasks such as, “Bring me the moon in a teacup” result in the *Charm* being wasted.

N: The charmed player’s count starts the moment they are *Charmed*, except as noted above.

Circle of Protection (FE, Sorcery)

C: Healer 6, Wizard 2

M: 10 ft cloth

I: Lay cloth in circle, repeat x5 “Circle of protection,” place person(s) and/or item(s) you wish to protect inside.

E: Person(s)/item(s) inside can’t harm or be harmed by anyone outside the circle, nor can they cast magic that affects anyone or anything outside the circle. Forces outside the Circle of Protection may not affect them.

L: Can’t block or restrict access to an area. Cannot be used as a cage. No one can enter without recasting the magic. Neither game items, nor persons acting as game items may be put inside. Protection starts when you step inside the cast circle.

N: Magic in the process of being cast inside the circle is broken when the circle is broken (e.g., No *Doomsday* circles). Players outside the circle can detect its presence (it is linked to this plane). May be removed by *Dispel Magic* or having an *Anti-Magic* fixed enchantment cast with the circle inside its area of effect.

Commune (S, Sorcery)

C: Druid 4

M: Tree

I: Touch tree with free hand, repeat x5 “Commune,” sit down with back touching tree.

R: Self

E: Caster may not harm others. Others within 20 feet may not harm or take hostile actions towards the caster.

L: Must be chanting “Commune,” keep back touching tree, and cannot be holding a weapon or game item or the magic is broken. Cannot be closer than 20 feet to a base or flag when *Commune* is started. May not interact with game items while in *Commune*.

Confidence (E, Sorcery)

C: Bard 3

M: Player

I: Touch player, repeat x5 “You are great and powerful,” tie enchantment cloth on target

E: While enchanted, player is considered one level higher. If a life was gained from the increase of level and the player died while enchanted, the loss is removed from the “extra” life and is otherwise not subtracted from his total. The player gains all abilities of the higher level.

L: Each player can have this cast on them only once each game. May not be cast on magic-users or monsters.

Confusion (S, Control)

C: Bard 5, Druid 3

I: Repeat x5 “By the power of my mind, I will thee to be confused.”

R: 50 ft.

E: Target must attack the nearest creature(s) for a 100 count (with magic if the target wishes). The target must look around for the nearest player before attacking, but can then attack that person until it is dead, or choose to change to another target that becomes closer. If the “closest” person is killed, the target must look around for a new target and continue until the 100 count is up.

L: Monsters are immune.

N: The affected player is encouraged to “role-play” the *Confusion*. Reeves are encouraged to penalize players who make only half-hearted attempts at this effect and to shorten the next death count of targets that play it well.

Cure Disease (S, Spirit)

- C: Druid 2, Healer 2
- M: An undead, diseased or like type creature
- I: Repeat x5 “I cure thy illness”
- R: Touch
- E: Converts diseased or undead creature back to human.
- N: This is not a *Resurrect* spell. If dead, the target must still come back to life normally.

Cure Poison (E/S, Spirit)

- C: Druid 1, Healer 1
- S: Spirit
- M: Enchantment cloth (if used as enchantment)
- I: Repeat x10 “Cure Poison,” tie cloth to person.
- E: Makes person immune to the next poison effect (but not the wound itself) against him, or may be used to cure poison on a person at time of casting.
- N: Is not a *Heal* spell, wounds remain after *Cure Poison* is cast.

Dance (N, Neutral)

- C: Bard 6
- I: State “Dance,” followed by the incantation of the spell it is to be used with, and ending with “The dance is now complete.”
- E: You may cast the altered spell while moving, but it must be cast within a 50 count.
- L: May only be used with spells from the caster’s class’s spell list.
- N: May be cast while moving. The spell enhanced by *Dance* is not cast until the ending phrase is also completed. *Dance* is cast as soon as “Dance” is said, even if the accompanying magic is not completed.

Defend (E, Protection)

- C: Wizard 6
- M: Enchantment cloth
- I: Repeat x5 “Power defend me.” Tie cloth on self.
- E: Caster is granted one Protect and one of the following: *Protection from Magic*, *Protection from Flame*, or *Protection from Projectiles*. Casting magic does not cause this enchantment to dissipate.

Dispel Magic (S, Sorcery)

- C: Healer 6, Wizard 3
- I: Repeat x5 “I dispel that magic.”
- R: 20 ft.
- E: If cast on a player, all spells and enchantments on a player are dispelled, including any enchantments on their equipment; *Reanimated* players die. If cast on an object, all enchantments on it are dispelled. May target a fixed enchantment to remove it.
- L: Not usable against relics. It does not affect Extraordinary class abilities or skills, nor does it affect the following: neutral magic of any type, any spell or enchantment already discharged (such as *Heal*), *Commune*, *Messenger*, *Teleport* in the act of being completed, *Lost*, or *Banish*. *Dispel Magic* can cancel *Anti-Magic* only if cast from the outside.
- N: Will cancel *Protection from Magic*. Will remove all enchantments from the target’s equipment even if not currently in the possession of the target. Example: Throwing down an *Imbued Weapon* sword will not prevent *Dispel Magic* from removing the enchantment.

Doomsday (S, Death)

- C: Wizard 4
- I: Count “Doomsday 1, Doomsday 2...” through “Doomsday 350.”
- R: Line of Sight
- E: All enemies in line of sight at the end of the spell die.
- N: Many large battlegame scenarios will prohibit the use of mass-effect spells like *Doomsday*.

Enhancement (N, Neutral)

- C: Healer 4
- E: May purchase three points worth of first, second or third level healer magic.

Entangle (B, Subdual)

C: Druid 1, Healer 2

M: Padded brown “Entangle” ball with streamers

I: Hold ball and repeat x5 “Entangle.”

E: Victim is stuck in place for 150 count. The victim may not move or communicate in any fashion, and neither the victim nor his equipment can be effected in any way – except where noted below. Engulfing.

L: Beings immune to Flame may not be freed by a *Fireball* or *Flameblade*. You may only have as many victims affected as you bought spell balls.

N: *Dispel Magic* or a touch from a weapon enchanted with *Flameblade* will instantly negate the effect. One *Fireball* striking the victim will instantly negate the effect. Multiple *Fireballs* striking the victim will cause the victim to be freed by the initial *Fireball*, and affected normally by any others. *Shove*, *Teleport*, and *Wind* may be used normally on an affected victim.

Expertise (N, Neutral)

C: Wizard 6

E: May purchase four points worth of up to second level magic.

Extension (N, Neutral)

C: Bard 3, Druid 3, Healer 5, Wizard 3

I: State “Extension” loudly before a spell.

E: Doubles range of the spell for one use. If the spell has a range of ‘Touch’, grants range of 20 ft and the caster must point at the target in lieu of touching.

L: May not be used more than once on the same casting (e.g., No doubling range twice).

N: The *Extension* is expended when “Extension” is stated, even if the accompanying spell is not completed.

Fear (S, Control)

See *Anne/Fear*.

Feeblemind (S, Control)

C: Druid 6

I: Point at victim, repeat x3 “By the power of my mind, I confuse and erase yours.”

R: 50 ft

E: Victim may not cast magic or use any abilities of their class. Victims may still fight with melee weapons.

L: Death or *Dispel Magic* will remove this effect.

N: Class abilities already in use when *Feeblemind* is cast continue to function. Example: A warrior may continue to use his **Improved Weapon** if already on a weapon, but would be unable to use his **Repair Item** ability.

Finger of Death (S, Death)

C: Druid 6, Wizard 4

I: Point at victim, repeat x5 “I call for your death.”

R: 50 ft

E: Person dies.

Fireball (B, Flame)

C: Wizard 4

M: Padded red “Fireball” with streamers

I: Hold ball in free hand and repeat x5 “Fireball.”

E: Destroys (or kills) anything it touches while moving, even on a roll or foot shot (it affects all targets it touches not just the first thing struck).

When throwing the caster may declare that the *Fireball* is “remain active.” If this is done, the *Fireball* will continue to burn for up to two minutes after it comes to a stop, destroying the very next thing it touches and ending the effect. Bounces count.



Flameblade (E, Flame)

C: Druid 5

M: Enchantment strip, edged weapon

I: Tie cloth to weapon, repeat x10 “Flameblade.”

E: Weapon becomes Red. This weapon now negates *Iceball* and *Entangle* hits to the wielder and frees other players from an *Iceball* or *Entangle* with a touch. The weapon itself is immune to further **Flame** magic.

L: This is not equal to, and should not be confused with, the relic **Sword of Flame**.

Flamewall (FE, Flame)

C: Druid 4

M: 10 ft. Long cloth.

I: Lay cloth in straight line, raise hands, repeat x5 “By the might of nature, I call forth a flaming wall.”

E: Creates a wall of flame. Anyone not protected who touches or crosses it will be killed. Melee cannot take place across wall.

N: *Protection from Magic* will not protect a player from this – though *Protection from Flame* will.

Flight (E, Sorcery)

C: Wizard 5

M: Yellow enchantment cloth

I: Tie cloth on self and state “Wouldn’t it be nice to fly way up in the cloudy sky, looking through the falcon’s eye, at the world that’s drifting by?”

E: Caster is able to fly as long as they flap their arms and emit occasional piercing screeches. Immune to melee attacks by non-flyers. Immune to projectile and magic ball attacks from within twenty feet. Caster may use verbal spells without losing the enchantment.

L: May only be cast on self. May not engage in melee combat with non-flyers.

N: Range for all game effects is considered to be the same as actual physical range. Loss of an arm will dissipate this magic.

Forcewall (FE, Sorcery)

C: Wizard 2

M: 10 ft. Cloth

I: Lay cloth out in straight line, repeat x10 “Forcewall.”

E: Creates an impenetrable 10-foot wall

N: Nothing may cross this wall. Nothing. Seriously. Not magic, not projectiles, not anything. Zero, zip, zilch, nada.

Harden (E, Protection)

C: Healer 4, Wizard 2

M: Enchantment cloth

I: Tie cloth on object, repeat x5 “Harden this (name of item).”

E: Makes object indestructible, except versus *Sphere of Annihilation*.

L: Cannot be placed on players, garb, armor or anything else that covers a player directly. May be cast on shields.

Heal (S, Spirit)

C: Druid 1, Healer 1

M: Person

I: Touch person and state:

“Sword Cut, spear stab, mace smash, arrow jab,
 Let the white light of healing descend on thee.
 Sword Cut, spear stab, mace smash, arrow jab,
 Let the white light of healing stop thy spilling blood
 Sword Cut, spear stab, mace smash, arrow jab,
 Let the white light of healing mend thy bones.
 Sword Cut, spear stab, mace smash, arrow jab,
 Let the white light of healing close thy wounds.
 Sword Cut, spear stab, mace smash, arrow jab,
 Let the white light of healing restore thy vigor.
 Sword Cut, spear stab, mace smash, arrow jab,
 The white light of healing hath healed thee.”

R: Touch

E: Person’s wound is healed.

N: May be used on self. Will repair one point of natural armor on any one hit location. Healers do not require a spell book or scroll to cast *Heal*.



Heal Extend (S, Spirit)

C: Healer 2

I: State “Heal Extend” then recite the *Heal* spell.

R: 20 ft.

Heat Weapon (S, Flame)

C: Druid 1, Wizard 1

I: Repeat x2 “By the power and might of the sun, I heat that (weapon).” Be specific, if possible.

R: 20 ft

E: The weapon is considered useless for a 300 count.

L: Works against any weapon, but not armor or shields. Someone protected against flame effects may continue to wield the weapon (but it does no additional damage and does not become a flame weapon).

N: *Mend* will not restore the weapon; however, a “new” one may be obtained as per destroyed items. *Heat Weapon* does affect *Hardened* weapons.**Hold Person** (S, Subdual)

C: Bard 1, Wizard 2

I: Repeat x3 “I command thee to stop.”

R: 20 ft

E: Victim may not move feet for 100 count. May yell, fight or cast any magic that does not involve moving feet.

N: May be cast while moving. Wizards do not require a spell book or scroll to cast *Hold Person*.**Honor Duel** (S, Sorcery)

C: Bard 4, Wizard 1

I: State “(the names of both contestants)” loudly and repeat x5 “Remain this duel pure.”

R: 20ft (Both contestants must be within 20 ft of the caster when the incantation is finished for the spell to work.)

E: Each contestant becomes completely immune to outside effects. They must duel each other until one is dead or a mutually agreed term of winning is accomplished. Participants in an *Honor Duel* may only affect one another and are considered to be out of play until the spell is finished. The victor may choose safe passage to their home base, ignoring all wounds until arrival. If alive, the loser must return to his base and call ‘Alive’ to re-enter the game.

L: May not be members of the same team without the Reeve’s permission. Barbarians cannot be involved in this spell. Spell is negated if no side achieves victory in a 300 count.

N: Combat is limited to a reasonable area. Should the duel become a stalemate (e.g., A participant is Petrified or otherwise incapacitated) the spell will be considered a draw if no combat takes place within a 30 count and both players must then return to base. *Honor Duel* may not be dispelled or cancelled. May not be cast on people acting as game items.**Iceball** (B, Subdual)

C: Wizard 1

M: Padded white “*Iceball*” with streamers.

I: Hold ball in free hand and repeat x5 “Iceball.”

E: Effects, Limitations, and Notes as per *Entangle*.**Imbue** (N, Neutral)

C: Bard 3

E: Allows the caster to purchase two magic points of up to second level bard magic.

Imbue Shield (E, Protection)

C: Wizard 1

M: Enchantment cloth, Shield

I: Shield in hand, repeat x10 “Imbue this shield,” tie cloth to shield so it is visible.

E: Shield may not be destroyed by any means except *Sphere of Annihilation*. The shield is not affected by other magic. Engulfing magic balls that strike the shield do not affect the holder of the shield. A *Fireball* that bounces off the shield will still affect legal targets that it strikes.

L: A hit from an Instant-Kill siege weapon will affect the bearer of the shield as per normal, though the shield itself is undamaged.

Imbue Weapon (E, Sorcery)

C: Wizard 4

M: Enchantment strip

I: Weapon in free hand, repeat x10 “Imbue this weapon,” tie cloth on weapon.

E: Wounds inflicted by the weapon kill.

N: *Imbue Weapon* is often referred to as “wounds kill” by players carrying the enchantment.

Immolation (FE, Flame)

- C: Druid 6
- M: Cloth used to denote a 10ft radius area.
- I: Lay cloth, touch cloth, repeat x5 “May the power of nature and the fire of the earth protect this area from intrusion.”
- E: Everyone within the area who is not immune to Flame is killed.
- N: *Protection from Magic* will not save you from this enchantment. Any person entering this area with invulnerability loses one point and is ejected from the point at which he entered. Against invulnerable armor this counts as one hit on every location and has a full effect on the target if any areas have no points of invulnerable armor.

Killing Grounds (FE, Death)

- C: Wizard 6
- M: Up to a 20 ft radius circle surrounded by a strip of cloth, tape, or rope
- I: To set trap, lay out cloth in a circle, repeat x3
 “Poison seep, venom creep, flesh in mossy graves yet deep
 Rise from thy undreaming sleep, bide and soon make mortals weep”
 To trigger, enter the circle and repeat:
 “Rise up now, receive thy pay, the promised time has come, now slay.”
- E: All within circle die.
- L: May not be used within 50’ of a base. No other fixed enchantment may exist within its radius, regardless of who cast it, and it cannot be cast if one is already in place, again regardless of who cast it.
- N: Caster dies when magic is triggered. If caster is killed before triggering the trap, the magic is not expended. Nothing will save the caster from his own *Killing Grounds*. This is the only fixed enchantment that may be pre-placed.

Legend (S, Control)

- C: Bard 2
- I: State “Legend,” followed by a short poem of 20+ words, and end with “Legended”
- R: 20 ft.
- E: The caster and victim move to an out of the way place within 50 ft of the casting of the spell, where the caster will perform for him. Neither the caster nor target can be attacked by anyone within a 20 ft radius. The caster may defend himself, but at the cost of canceling the spell. The victim may not do anything. Once the performance has begun, anyone susceptible to control magic may be ensnared, at the caster’s option, if they come within 20 ft of the bard while he is performing. He may attempt to ensnare a maximum number of people equal to his level. Unsuccessful attempts to ensnare a victim still count towards this limit. To start his performance he states “I will now give a performance” x5 so that it can be heard at least 50ft away.
- L: The “out of the way place” cannot be within 50 ft of a base. Performance has a maximum length of a 300 count (started the moment the spell is finished being cast). If ended without the death of the target(s), the targets must tag their base before returning to the game. Players not affected by *Legend* may not attack, cast magic, or use class abilities on the bard or his victims if within 20 ft of the caster’s performance but may enter and leave the area at will.
- N: The caster may attack victims of this spell, though the caster attacking anyone in a *Legend* frees all other victims and the *Legend* spell is broken. The caster and victim are considered removed from the game during their transit to the performance location. This is considered an ongoing spell effect and as such may be removed via *Dispel Magic* targeted on the caster.

Lend (N, Neutral)

- C: Wizard 5
- E: May *Lend* magic to another magic-user of the same class. That person may then use the magic as if he had purchased it with his own points. The caster lending the magic may no longer use it.
- N: To *Lend* a magic, the caster must pay for both the *Lend* and the magic he is *Lending*. *Lend* must be decided, bought and paid for before the game begins.



Lich (E, Spirit)

C: Wizard 5

M: 10 ft. Strip of yellow cloth. Monster handout (Lich)

E: After having died his last natural death, the caster returns as a *Lich*. A *Lich* is bound to the place where he died, trapped within the small circle of earth indicated by the 10 ft. Cloth. They are neutral (not on any team), but like any monster can be bribed or convinced for help or enchantments.

L: May not be within 100 feet of a base. May never move nor be moved except when dead. While the caster is dead, he may be moved but not more than 100 feet from his original location, and still not within 100 feet of a base.

N: A *Lich* has all the casters per life spells as though it is an additional life plus all other magic the caster had not yet expended before becoming a *Lich*. A *Sever Spirit* or *Dispel* will kill a *Lich*. A *Lich* is considered to be a caster and undead and may still die from normal means.**Lightning Bolt** (B, Flame)

C: Wizard 2

M: Padded yellow “Lightning Bolt” with streamers

I: Hold bolt in free hand and repeat x5 “Lightning Bolt.”

E: Players struck die; Items struck are destroyed.

Liplock (E, Sorcery)

C: Bard 2, Wizard 2

M: Enchantment cloth

I: Repeat x5 “Remain the truth still,” tie on cloth.

E: Bearer cannot speak or otherwise respond to questions asked under *Talk to Dead* or similar magic. Does not affect the **Tracking** ability.

L: May only be cast on each player once per battlegame.

N: Disappears when the person comes back to life. May be cast on an unwilling target.

Lore (S, Control)

C: Bard 4

I: State “Lore,” followed by a short poem (20 words or more), and ending with “Lore.”

R: 20ft

E: The caster and target are removed from the game. The caster then may ask the victim a ‘yes’ or ‘no’ question, which must be answered truthfully. The caster may continue asking questions until he receives a ‘no’ answer – in which case, the spell ends. If the target does not know the answer of the question, he may state so, but it does not end the spell. The reeves might give the bard additional information to further define the *Lore* spell. (Very useful in Quests and special scenarios).

L: The questioning has a maximum time count of 100. The caster and target may not attack each other during the duration of the spell and for a 100 count after its completion.

N: Neither the caster nor the victim may move about while the questions are being asked.

Lost (S, Subdual)

C: Healer 1

I: Repeat x5 “I make thee lost.”

R: 20 ft.

E: Person must go back to their base or Nirvana (whichever is farthest away) before they can do anything else. The person is out of game until he reaches his destination.

L: May not be used on Teammates.

N: May not be dispelled.

Magic Bolt (B, Sorcery)

C: Wizard 1

M: Padded blue “Magic Bolt” with streamers

I: Hold ball in free hand and repeat x5 “Magic Bolt.”

E: A direct hit on a person will kill or wound them just as if it were a throwing weapon. May be blocked by shields and weapons. Destroys one point of armor.

N: It is not stopped by *Protection from Projectiles*. **(Greater) Missile Block** is ineffective against this.

Magical Projectile (E, Sorcery)

C: Druid 2

M: Projectile (arrow, javelin, throwing knife, etc), enchantment cloth.

I: Hold projectile in free hand, repeat x5 “May this projectile strike true,” tie cloth to projectile weapon.

E: Projectile will do one more point of damage than normally done by the projectile type. If this increases the damage to five points or more, the projectile damages shields as a red weapon that can be counted as strikes on shields even when used as piercing weapons.

L: Monks may still block these projectiles without penalty.

N: This enchantment may be simul-cast up to four times, providing four additional points of damage to the projectile.

Mass Sleep (S, Subdual)

C: Healer 3

I: Repeat x300 “Mass Sleep (present count).”

R: Line of sight.

E: As per *Sleep*, except effects everybody (both teams) in line of sight.

Mend (S, Sorcery)

C: Druid 2, Healer 1, Wizard 2

I: Repeat x10 “Make this item whole again.”

R: Touch

E: Will repair a destroyed item or restore one point of armor in one location.

L: Cannot be used to negate the affects of *Heat Weapon*.

N: If an enchanted item is *Mended*, its enchantment stays intact.

Messenger (E, Sorcery)

C: Wizard 2

M: Enchantment cloth

I: Cloth in free hand, repeat x10 “Safe passage unto thee,” tie cloth on player.

E: Recipient must go straight to destination, deliver message, then return where spell was cast. Cannot harm others nor be harmed, and may not be followed.

Mimic (N, Neutral)

C: Bard 5

M: Wear a sash of the class you are mimicking in addition to your bard sash. The new sash must be worn on the opposite hip and shoulder from the caster sash.

E: During life used caster gains all the non-magical 1st level abilities and restrictions of a single standard class that is mimicked, including all weapons, armor and shields permitted that class at 1st level. The caster may also still use his normal class abilities.

L: May not be used to *Mimic* the Anti-paladin or Paladin classes unless caster is a knight.

N: If Berserk, caster may not cast magic. Monsters may never be mimicked.

Mute (S, Control)

C: Bard 5, Healer 1

I: Repeat x5 “I silence thee.”

R: 20 ft.

E: Victim cannot speak or cast magic for a 100 count.

N: Speaking requirements used in class abilities to allow others to know what the player is doing (sanctuary chant, etc) are not affected and may still be used.

Mutual Destruction (S, Death)

C: Wizard 3

I: Repeat x5 “I call for our deaths.”

R: 50 ft.

E: Both the caster and the victim die.

N: Nothing will protect the caster from his own *Mutual Destruction*.

Petrify (B, Subdual)

- C: Druid 5
- M: Padded gray “petrify ball” with streamers
- I: Hold ball in free hand, repeat x5 “Petrify.”
- E: Victim is stuck in place, a stone statue. The victim may not move or communicate in any fashion until the game is finished. He and his equipment cannot be harmed. Engulfing.
- L: A ball may not be reused if the spell is in effect (on a victim), but may be reused once the victim is free.
- N: *Release* or *Dispel Magic* will instantly free the victim, while *Heal* will free the player in a 150 count starting from when the *Heal* is completed. *Shove*, *Teleport*, and *Wind* may be used normally on an affected victim, but he may not otherwise be moved. No other magic will affect them. A player who takes a death while under the effect of *Petrify* may not in any way return from the dead, with the obvious exception of his normal death count, until a *Summon Dead* has been cast on the corpse.

Plant Door (S, Sorcery)

- C: Druid 3
- M: A tree taller than the caster.
- I: Touch tree with both hands, repeat x5 “Open up and receive a loyal protector of the forest.”
- R: Self
- E: Caster is assumed to be inside the tree, and may not be attacked. May cast Verbal magic, but must touch the tree or spell ends.
- L: If the tree is hit 10 times by a slashing weapon, or if a flame effect strikes it, it is destroyed and the caster is no longer protected. The caster may not fight with weapons while the spell is in effect. The caster may be affected by Verbal magic while he is casting magic.

Presence (N, Neutral)

- C: Bard 1
- M: When used, must tie a blue ribbon upon an arm
- E: Due to respect and awe for the position, all barbarians will not attack the caster during a life in which *Presence* is used. Also, due to professional respect, druids and monks of lower level than the caster will not attack the caster.
- L: If the caster attacks or casts magic at a barbarian, monk, or druid who is affected by *Presence*, that person may ignore the affects of the caster’s *Presence* for the rest of the game.
- N: Players that are **Berserk** ignore *Presence*.

Protect (E, Protection)

- C: Healer 3, Wizard 3
- M: Enchantment cloth
- I: Repeat x10 “May this magic Protect thee,” tie cloth on person
- E: Person enchanted is immune to the first hit of any kind or the first magic cast against him. This is one level of invulnerability.
- N: May be simul-cast up to two times on the same person, protecting against the next two hits. May not be *Mended*.

Protection from Control (E, Protection)

- C: Bard 1
- M: Enchantment cloth
- I: Repeat x5 “Thou art Fearless and Brave,” tie cloth on target.
- E: Target is immune to Control magic and abilities.

Protection from Death (E, Protection)

- C: Healer 5
- M: Enchantment cloth
- I: Repeat x5 “I protect thee from death,” tie cloth on person
- E: Target is immune to Death magic and abilities.

Protection from Disease (E, Protection)

- C: Druid 3, Healer 3
- M: Enchantment cloth
- I: Repeat x5 “I protect thee from disease,” tie cloth on person.
- E: Person is immune to all forms of disease.
- N: This will protect a person from being converted to an undead or lycanthrope.

Protection from Flame (E, Protection)

C: Druid 3, Wizard 2

M: Enchantment cloth

I: Repeat x10 “Protection from the element of fire,” tie cloth on person or object.

E: Protects against all forms of flame, including all magic of the Flame School. Treat the relic *Sword of Flame* and a sword enchanted with *Flameblade* as dealing ordinary hits.N: Negates a *Fireball*'s negation of *Iceball* and *Entangle*.**Protection from Magic** (E, Protection)

C: Wizard 4, Healer 6

M: Enchantment cloth

I: Repeat x10 “Protection from all forms of magic,” tie cloth on person or object.

E: Blocks all forms of magic, even beneficial magic such as *Heal* and *Resurrect*.N: Treat weapons with *Imbue Weapon* cast on them as normal weapons.**Protection from Projectiles** (E, Protection)

C: Wizard 3

M: Enchantment cloth

I: Repeat x10 “Protection from projectiles,” tie cloth on person or object.

E: Protects from all non-magic projectiles.

L: Ineffective against magic balls, the *Dagger of Infinite Penetration*, and weapons bearing *Magical Projectile*.

N: Will stop Siege Weapons that are projectiles.

Protection from Subdual (E, Protection)

C: Bard 2

M: Enchantment cloth

I: Repeat x5 “Thou shall have freedom of movement,” tie cloth on target.

R: Touch

E: Target is immune to subdual magic and abilities. Target also gains immunity to being subdued or held in place by any means except for the *Stun* spell.**Pyrotechnics** (S, Flame)

C: Druid 4, Wizard 4

I: Repeat x5 “I call upon the element of fire to destroy that (object).”

R: 50 ft.

E: Object is destroyed.

L: May be repaired by a *Mend*. Does not affect bases, relics, game items, items bearing the *Harden* enchantment, *Imbued Shields* or any enchantment. Is stopped by *Protection from Magic* and *Protection from Flame*.**Reanimate** (E, Spirit)

C: Wizard 5

M: Enchantment cloth

I: Repeat x10 “Rise and fight again,” tie cloth on player

E: Player temporarily comes back from the dead to loyally serve the caster. This enchantment lasts for a 200 count or until the player's death count is finished. When the time has elapsed the player is once again dead and may return to life when his normal death count has expired, or immediately at his base if his death count expiring ended the *Reanimate*. Any player having *Reanimate* cast on them is affected as per *Sever Spirit*.L: *Dispel* will kill. Wounds (other than the one which killed) and damage to armor remain, but may be *Healed* or *Mended* as normal. Reanimated players may not use magic or per life/game abilities though any that were already in effect already (i.e. A warrior who had already **Improved** their shield would retain his **Improved Shield**).N: As *Reanimate* is an enchantment, person does not retain enchantments carried before death unless they are able to bear two enchantments (e.g., 6th level scouts and wizard *Stack*). Even if this is the case, if they were bearing two enchantments only one may be retained.

Regeneration (E, Spirit)

C: Druid 5

M: Enchantment cloth, player

I: Repeat x5, "Endless health unto thee," tie cloth to person.

E: Players bearing this enchantment will *Heal* a single wound in a 50 count and are immune to poison. The player may not be fighting to gain this benefit. Fighting will interrupt the *Heal* count and cause the player to have to start over when they stop fighting. The last five seconds of the *Heal* count must be said aloud and audible to fifty feet.

L: You must be alive to gain the benefits of this enchantment. Will not work on armor of any sort.

Reincarnate (E, Spirit)

C: Druid 6

M: Dead person, appropriate garb, monster handout

I: Repeat x3 "I call thy spirit back from the realm of death, inherit this new form and serve me until thy destruction."

E: Player sacrifices lives (listed in the monster section) to play as a monster with one life.

L: Restricted to the following monsters: Lizard man, Dryad, Unicorn, Hill Giant, Regenerating Troll, Centaur, Brownie and Siren. Must be approved by the appropriate group officers.

N: The garb for the monster must meet required standards. Once the monster dies, it is out of the game. May be removed via *Dispel Magic*. Player does not get the sacrificed lives back if this is done. *Reincarnated* players no longer play by their class rules, but by the rules of the class they have become.

Release (S, Sorcery)

C: Healer 4, Bard 6, Druid 5

I: Repeat x3 "From thy bindings thou art released."

R: 20 ft

E: Dispel the effects of one subdual or control magic such as *Yield*, *Entangle*, or *Petrify*, upon the target. Target is immediately freed.

N: If cast on someone in a *Legend*, they may not be retargeted by that *Legend* spell for its duration.

Resurrect (S, Spirit)

C: Healer 3

M: Dead Person

I: State once:

"Sword Cut, spear stab, mace smash, arrow jab,

Let the white light of healing descend on thee.

Sword Cut, spear stab, mace smash, arrow jab,

Let the white light of healing stop thy spilling blood

Sword Cut, spear stab, mace smash, arrow jab,

Let the white light of healing mend thy bones.

Sword Cut, spear stab, mace smash, arrow jab,

Let the white light of healing close thy wounds.

Sword Cut, spear stab, mace smash, arrow jab,

Let the white light of healing restore thy vigor.

Sword Cut, spear stab, mace smash, arrow jab,

The white light of healing hath resurrected thee."

R: Touch

E: The dead person is alive again, negating the last death and removing all negative effects on the player such as *Yield* or *Poison*.

L: A dead person cannot move on his own nor speak in order to encourage a caster to *Resurrect* him. A person that moves from where they died (barring removing oneself from impeding play) cannot be *Resurrected* unless a *Summon Dead* spell is used first. Will not turn monsters back to human. Monsters created by magic may not be *Resurrected*. All wounds and damage to natural armor the dead person had prior to dying are repaired.

N: A dead person may remain on the field as long as he wishes, but may not affect the battle or impede play. Enchantments not eliminated by combat effects or not specifically prohibited may be retained by a *Resurrected* person.

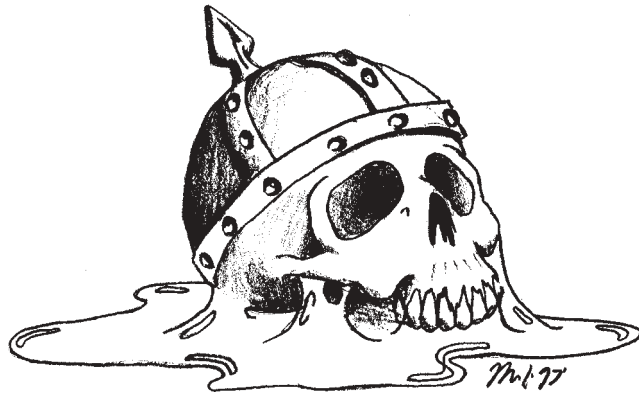

Sever Spirit (S, Spirit)

C: Healer 4, Wizard 4

M: Already dead victim

I: Repeat x2 "On life thou has no hold, thy corpse is growing cold, discard this empty husk, thy spirit resides at dusk."

R: Touch

E: Causes corpse to be impossible to *Resurrect*, *Reincarnate*, *Transform*, or raise from the dead in any manner.

L: May only be used on dead bodies (undead creatures must be killed and then *Cured* before this spell will work on them, though see below).

N: Will permanently kill undead creatures that are on their last life and will kill a *Lich* outright. May be used on any player that has not yet reached Nirvana, even if they have moved from where they died.

Shove (S, Sorcery)

- C: Wizard 1
- I: Repeat x5 “I shove thee.”
- R: 20 ft.
- E: Forces victim to back up 20 feet.
- L: Cannot force a person into a mundanely physically dangerous position.
- N: Will work against persons under effects of *Iceball*, *Entangle*, *Petrify*, and *Sleep* magic.

Silence (FE, Sorcery)

- C: Druid 4
- M: 20 ft. Measure, Green markers for 20' radius
- I: Set up markers, stand in middle with both hands above head and repeat x5 “May no form of sound, speech or noise be heard in this place.”
- E: No speech (talking), including magic casting, is allowed in the enchantment’s radius. Magic may be cast into or through *Silence*, however.
- N: Speaking requirements used in class abilities to allow others to know what the player is doing (sanctuary chant, etc.) Are not affected and may still be used.

Sleep (S, Subdual)

- C: Bard 3, Healer 2
- I: Repeat x2 “Listen and let the fighting cease, close thy eyes and sleep in peace.”
- R: 20 ft.
- E: Victim must lie down and “Sleep” for a 100 count.
- L: *Sleeping* people cannot be killed. The target and their possessions may not be harmed. The target may not be moved except via the *Shove* and *Wind* spells. The target’s possessions may not be removed from his person. This spell may not be *Cancelled*.

Sphere of Annihilation (B, Sorcery)

- C: Wizard 6
- M: Black padded “sphere” ball with streamers.
- I: Hold ball in hand and repeat x5 “Sphere of annihilation.”
- E: Will destroy anything it touches; even *Imbued* or *Hardened* items. Counts as one hit against invulnerability. Is not stopped by any non-invulnerable armor. Weapons and shields are considered separate from the person holding them. Objects destroyed by *Sphere* may not be *Mended*. Will stop Fight After Death. Players killed by *Sphere* may still be *Resurrected*.
- L: Bounces do not count. Invulnerability does work against this magic, and *Protection from Magic* stops this.
- N: A player may only have one magical ball for this magic.

Stack (N, Neutral)

- C: Wizard 6
- M: Tie ribbon on arm of person receiving extra enchantment.
- E: You may place one extra enchantment on a single player or his equipment.
- L: May not be used on self, nor may it be *Stacked* on itself. May not be used with enchantments cast by other players. **Attuned** and this magic do not stack.
- N: The cost must still be paid for the two enchantments to be used.

Stoneskin (E, Protection)

- C: Druid 4
- M: Enchantment cloth
- I: Touch recipient, repeat x5 “May nature protect thee from all forms of attack,” tie cloth to players arm.
- E: Player gains one point of invulnerability (as per *Protect*) and one point of armor (as per *Barkskin*).
- L: Cannot be used with any other armor.
- N: This enchantment can be simul-cast up to two times, giving the target two points of invulnerability under two points of armor. May be cast on players that cannot normally wear armor.

Stun (S, Sorcery)

- C: Healer 3
- I: Repeat x 2 “By the radiant power of pure white light I stun thee.”
- R: 20 ft.
- E: Affected player may not move, speak, cast magic, fight, or use class abilities for a 100 count. They are considered completely senseless to the world around them.

Stun Weapon (E, Subdual)

- C: Wizard 1
- M: Enchantment cloth
- I: State “May this weapon stun its victim,” tie cloth to weapon.
- E: Allows a thrusting weapon such as a spear or arrow to be used to subdue.
- L: Does not allow the weapon to affect monsters that are only affected by magic weapons.

Summon Dead (S, Spirit)

- C: Healer 5
- I: Repeat x5 “I summon thy corpse.”
- R: 50 ft.
- E: Dead person may return to the healer but is not again alive.
- N: May be used on people in nirvana (if in range); this does not interrupt the count on a person’s death. The player is not compelled to return to the caster, but only has the option to do so. The spell is expended either way.

Swords to Plowshares (S, Spirit)

- C: Healer 2
- I: Repeat x2 “Cast down your weapons and return to the earth”
- R: 20 ft.
- E: Target wounded person is healed of all wounds. One weapon carried or wielded by target is destroyed (casters choice).
- N: May only be used on a wounded person carrying or wielding weapons.

Talk to Dead (S, Spirit)

- C: Bard 2, Healer 1, Wizard 1
- M: Dead Person
- I: Repeat x10 “Speak to me.”
- R: Touch
- E: Dead person must answer one “yes or no” question truthfully with “yes,” “no,” or “I don’t know.”

Teleport (S, Sorcery)

- C: Druid 5, Healer 6, Wizard 4
- I: Repeat loudly x5 “Teleport;” upon arrival loudly x5 “Arriving.”
- R: Touch
- E: Target goes to any one location of the caster’s choice. Cannot harm others nor be harmed during transit. Treat as Out of Game until at location, and may not be affected until the final “Arriving” has been stated. Example: A player casts *Teleport* and chooses as his destination the base of his enemy. The enemy cannot notice his transit to the area, but does notice when he starts repeating “arriving” and may not affect him in any way until he finishes the final “arriving.”
- L: Must go straight to location. Should quietly tell reeve or teammate destination. May not be followed (Exception - **Tracking**). Location must be a fixed location, cannot be something like “Where the bandits are hiding the captives” if this location is not known. Cannot be used on unwilling targets and attempting to do so results in the spell being wasted.

Thornwall (FE, Sorcery)

- C: Druid 2
- M: 10 ft. Brown and green cloth.
- I: Lay cloth in straight line, raise hand in air, repeat x10 “Thorns come forth.”
- E: Creates a 10 ft long impassable wall of sharp thorns.
- L: This wall can be destroyed by 10 hits with a melee weapon, or a hit from a flame effect (*Fireball*, *Flameblade*, **Flame Arrow**, etc). If struck by a flame effect, the wall is treated as a *Flamenall* for a 100 count before being consumed and disappearing.

Touch of Death (E, Sorcery {Effect is Death})

- C: Healer 4, Wizard 3
- M: Enchantment cloth
- I: Repeat x20 “Touch of death,” tie strip on person.
- E: Bearer of enchantment’s touch kills (via either hand).
- L: Will work through clothing, but not armor of any sort.
- N: Does not have to be discharged on the next person touched after the enchantment is cast, but can be saved until it is needed; must be announced when discharged. The magic itself is Sorcery, but its effect when released is Death magic. Targets may not be touched in an illegal, dangerous, or offensive manner. Counts as one hit against invulnerability and invulnerable armor. One use only.

Touch of Paralyzation (E, Sorcery {Effect is Subdual})

- C: Druid 2
- M: Enchantment cloth
- I: Repeat x10 “Paralyzation.” Tie cloth on person.
- E: If bearer of this enchantment touches a player, that player is paralyzed and may not move for a 100 count. Bearer must state “Paralyzation” to the victim as he delivers the touch. The effects are similar to a subdual blow.
- L: Will work through clothing, but not armor of any sort.
- N: Does not have to be discharged on the next person touched after the enchantment is cast, but can be saved until it is needed; must be announced when discharged. The magic itself is Sorcery, but its effect when released is Subdual magic. Targets may not be touched in an illegal, dangerous, or offensive manner. Counts as one hit against invulnerability and invulnerable armor. One use only.

Transform (E, Sorcery)

- C: Wizard 6
- M: Appropriate monster garb and monster handout
- I: As player dresses in monster garb, caster constantly repeats “I transform thee into a (Monster being transformed into).”
- E: Player sacrifices lives as listed in the monster section to play a monster for one life.
- L: When a player is playing a summoned monster, their player persona is considered out of the game, and is not used. If the monster has levels, the player may play the monster at his class level or monster level, whichever is lower. For example a player is a second level wizard who is being transformed into a Pegasus. The player playing the wizard is also a fourth level monster. When summoned, he plays his Pegasus as a second level Pegasus. If he were a fourth level or higher wizard, he could have played the Pegasus as at fourth level (his monster level). Restricted to the following monsters: Mummy, Dryad, Unicorn, Siren, Goblin, Pegasus, and Skeleton. Must be approved by the appropriate group officers.
- N: The garb for the monster must meet required standards. Once the monster dies, it is out of the game. May be removed by *Dispel Magic*, thus killing the monster. Player does not recover the sacrificed lives back if this is done. Transformed players no longer play by their class rules, but by the rules of the monster class they have become.

Truth (S, Control)

- C: Bard 2
- I: State “Truth” followed by a single yes or no question.
- R: 20 ft
- E: The target must answer the question truthfully. If the answer is unknown the target may state so, thus ending the spell.

Visit (N, Neutral)

- C: Bard 1
- I: State “Visit” followed by a 150 count, during which the caster may make no hostile actions or the magic must be restarted. The caster may defend himself if directly threatened, but must disengage as soon as possible. The count is not a casting action, but time required for the *Visit* to take effect and must be counted so it can be heard 50 ft away. The caster must remain at his base during this count or the magic must be restarted. Is not used up until count is successful.
- E: The caster may enter and sit within/at the enemy base and/or position, and perform and talk with them. During this time neither the caster nor the enemy may attack one another or cast hostile magic at each other. To end the “*Visit*” the caster must declare that he is leaving and tag his base before returning to the game.
- L: Monsters may choose to ignore *Visit* and attack the caster.

Vivify (N, Neutral)

- C: Wizard 5
- E: Gives the caster one additional life.

Voice (N, Neutral)

- C: Bard 6
- E: Allows the caster to purchase five magic points worth of druid magic from any level. Magic bought is considered to be druid magic, regardless of the class of the caster.
- L: May not be used to purchase neutral magic. *Voice* does not allow the caster to exceed the maximum number of uses of the magic that may be purchased i.e. You may only purchase up to two *Fingers of Deaths*. You may not purchase any druid magic that is also on your native spell list.

Warp Wood (S, Sorcery)

C: Druid 1

I: Repeat x2 “By the power of nature I warp that (object).”

R: 20 ft.

E: Item is considered useless until *Mended* or dispelled.

L: Only works on objects made of wood such as: arrows, bows, shields, spears, pole arms, madus, staves, and any other game item declared to be wooden. Does not work on armor, unless it is wooden armor.

N: *Warp Wood* will not affect *Hardened* items or *Imbued Shields*.

Warskill (N, Neutral)

C: Bard 4

E: Caster may use a single weapon (not weapon type) at no cost to spell points.

Wind (S, Sorcery)

C: Wizard 3

I: Repeat x2:

“Sleeping force of Wind I hail, send you forth a mighty gale.

Gentle sigh which once beguiled, make your breeze tornado wild

Sirocco into cyclone gain, breeze become a hurricane.

Make my enemy your foe; strike for me a telling blow.

Scream down from the mountains high; sweep those fighters towards the sky.

Coward, hero, fool the same, trapped within this deadly game.

Strike at foes, leave friends behind, bite them with your teeth unkind.

Buffet, whip them to the bone, toss them in a pile at home.

Then whisper a gentle song, and return where you belong—

Nestled ‘gainst the azure sky, song in forest, willows’ sigh.”

R: Line of Sight

E: All enemies in sight are blown back to their base and considered out of game until they arrive.

Wounding (S, Death)

C: Healer 3, Wizard 2

I: Repeat x2 “From my heart I strike off your (right or left/arm or leg).”

R: 20 ft.

E: Victim’s limb is wounded.

L: The victim must be unwounded prior to spell casting.

N: May be cast while moving. Wizards do not require a spell book or scroll to cast. Has no effect on an injured player. Will outright kill monsters that die on wounds.

Yield (S, Control)

C: Bard 5, Healer 3, Wizard 3

I: Repeat x3 “Yield thy arms and resist no longer, come unto me and be my captive.”

R: 50 ft.

E: Victim lowers weapons and surrenders to the caster, moving in a straight line at a brisk walk – until at the caster’s side – where they then begin a 300 count. During this spell they stay by the caster’s side and cannot fight, cast magic, or use abilities. The caster may free the victim at any time for any reason. If they are not killed before the spell ends, they must return to their base, and are then able to act freely. May not be physically restrained to prevent the player from returning to base or going to the caster. If the caster dies the player remains near the body until their count expires.

N: Other magic may still affect the victim during the duration of *Yield*.

Monsters

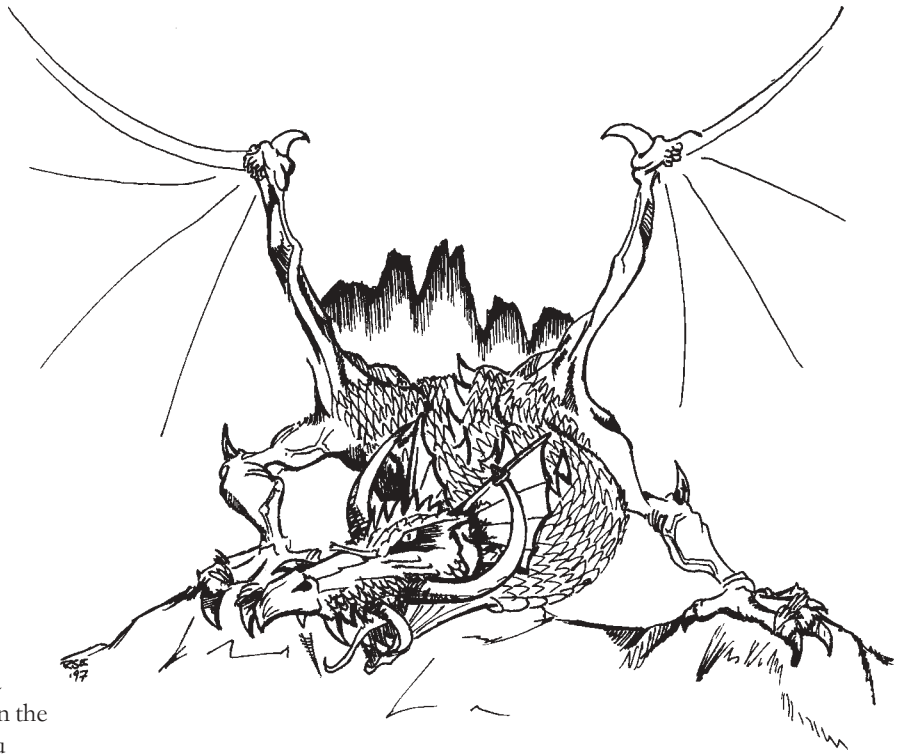

Monsters are listed in much the same ways as normal classes, though monsters tend to have a much larger list of special traits and abilities than the normal classes do. When playing a monster, you must always carry a complete description of the monster with you, have a copy for the reeve, and wear appropriate garb. If you are a wizard or druid casting summoning magic, note that both the garb and the descriptions are part of the magic component. There are a number of ways you can play a monster in a game. They include:

Standard Battlegame:

You must get the permission of the Monarch and the Prime Minister, and cannot play Quest monsters, or monsters with a 4:1 or greater ratio. If you play a monster with a ratio of 2:1 or 3:1, when you are added to a side, the other side then gets to pick 2 (or 3 if 3:1) people for the other side. Playing monsters with a 1:1 ratio does not alter how teams are picked.

Level: When playing a monster in a standard battlegame, you play the monster as your standard monster level.

Summoned Monsters:

Some monsters can be summoned in a standard battlegame. These do not normally require reeve's permission, though a reeve can always state what can and cannot be used in a battlegame. When playing a summoned monster, a player will sacrifice lives to play the monster for one life. That player will be considered enchanted. If a player is dispelled while playing a summoned monster, it kills him instantly.

Player lives/life: This is the number of lives a player has to give up to play this monster for one life. The player cannot gain more than one life as a monster unless otherwise stated in the monster description. Players cannot give up lives they do not have. Monsters who are killed cannot be reanimated. If *Resurrected*, or given a life by a monk, they return as their normal class, not as the monster.

Level: When playing a summoned monster, a player's level is that of the class lives were sacrificed from or that player's level in monster – whichever is lower.

Quests:

Quests are simply special battlegames. The reeves and designers of these make special rules, and often have special monsters, which are not used in the standard games.

Level: When playing monsters in Quests and other special battlegames, the designer of the Quest or the reeve will generally set each player's monster level based on what they wish or require. Summoned monsters still have the restrictions in level.

Monster Definitions

Monsters are listed much as the player character classes, though they have a few more aspects to them.

Garb: A person playing a monster should look as much like it as possible. The reeve can always disallow someone playing a monster if they feel this criteria is not meet. Summoned monsters should be given slightly more latitude, but they must have the minimum garb requirements and act in character.

Summonable Monsters: These monsters can be brought into the game by player magics.

When a player is playing a summoned monster, their player persona is considered out of the game, and is not used. If the monster has levels, they may play the monster at their class level (of the class they sacrificed lives from to play the monster) or their monster level, whichever is LOWER. For example a player is a 2nd level wizard who is being Transformed into a pegasus. The player playing the wizard also is a 4th level monster. When summoned, he plays his pegasus as a 2nd level pegasus. If he were a 4th level or higher wizard, he could have played the pegasus as at 4th level (his monster level). Note: Summoned monsters die if they enter an *Anti-Magic* zone. If a monster is summonable, they will list the following:

Summonable by: This will list the class and magic needed to bring them into the game.

Player lives/life: This is the number of lives a player has to give up to play this monster for one life. The player cannot gain more then one life as a monster (except for the goblin, as listed in the goblin's description) per magic cast on them. Players cannot give up lives they do not have. Monsters who are killed cannot be reanimated. If *Resurrected*, or given a life by a monk, they return as their normal class, not as the monster.

Q/M Ratio: This is a general indicator of how powerful the monster is. It defines how many player characters of the same level as the monster should be required to kill the monster. When designing Quests, one uses this number to balance the sides. This assumes you use the 10 to 1 rules for magic casters & 5 to 1 rules for archers.

Shields: Due to the very infrequent use of shields, monster denote if they can use them in their armor descriptions.

Natural Lives: While summoned monsters usually only have one or two lives, monsters used in Quests use the Natural number of lives listed for the monster. If extra NATURAL lives are gained through leveling, summoned monsters ARE NOT given an extra life.

Type: There are a number of monster types, each with special information regarding it. Some monsters are more then one type of creature.

- a. **Animations:** These creatures are immune to control, subdual, and death magic as well as poison. If a *Dispel Magic* is cast on them, they act as if under the effects of an *Iceball*. If place in an *Anti-Magic* field, they act as under a *Petrify* spell until the field is removed or they are removed from the field in which case they act as if just healed from the *Petrify*. These cannot carry enchantments.
- b. **Beast:** These are non-humanoid creatures, most often with more then two legs.
- c. **Extra-Planar:** These creatures are not from our world but another. They include angelic creatures, demons, and elementals. Extra-Planar creatures are immune to Death magic and poison. These cannot carry enchantments save for the one used to summon them.
- d. **Fey:** These are fairy folk. They are not immune to Bardic Charm (Control magic cast by bard), but are immune to other forms of Control magic.
- e. **Humanoid:** These creatures have 2 legs and walk upright. Only humanoids can use normal weapons and shields, creatures without this designation can only use their natural weapons.
- f. **Mystical:** Mystical Creatures hit with a *Dispel Magic* lose all their magic-like abilities and innate abilities for that life. They may not use their magical or innate abilities while in an *Anti-Magic* zone.
- g. **Multi-Person:** These are monsters played by multiple people. They have a number of special rules, detailed individually for each one. They are ALWAYS Quest monsters.
- h. **Undead:** These are immune to Control and Death magic as well as poison. These cannot carry enchantments save for the one used to summon them.



Traits: Traits are attributes that function all of the time without activation being required. This includes things like extra lives, immunities, the ability to regenerate, etc.

Magic-caster: Monsters with magic ability will list what class magics they get, what level they get them at, and how many points they get. Natural weapons never count against magic points.

Innate Abilities: These are abilities the monster has that have a limited number of uses. In many cases they act just like magics. These require the person to stand still as per casting a magic unless noted otherwise. If a School is listed, a magic that protects from that School, protects from the abilities. Otherwise only invulnerability will protect from the ability (though some have immunity to poison and traps, and thus are unaffected by them). Unless listed as magical, they are non-magical in nature. Magical innate abilities cannot be used in *Anti-Magic* areas and are stopped by *Protection from Magic* on those they target.

Magic-Like Abilities: These are magical abilities of the class that act in all ways as per the magic listed, save they do not cost magic points, do not require a free hand, and are given a number of uses. These cannot be used in *Anti-Magic* areas. These require the person to stand still as per casting a magic.

Vulnerabilities:

These are special magics or effects that break the rules. They take precedence over immunities. For example air elementals are immune to subdual magics, but have *Iceball* listed as a vulnerability, and as such are affected by it as described.

Description: This is a description of what the monster represents and would look like if it really existed.

Terrain Effects (for Quests and battlegames):

- a. **Anti-Magic:** Denoted with yellow ribbon placed in the area. Magic does not function within these zones.
- b. **Death Field:** Denoted with black ribbon. Those who are not immune to death magic die if they enter this area.
- c. **Flame (lava, etc):** Denoted with orange ribbon placed around the area. These are areas of open flame. Beings without *Protection from Flame* are killed if they move through it (or lose point of invulnerability or invulnerable armor chest for each second they stay touching the area). Beings protected from flame, and all equipment they are carrying are immune to this effect.
- d. **Water:** Denoted with silver tarp on ground or silver tape placed around the area. Any non-Aquatic, non-large, or non-flying creature entering this area must drop to their knees while moving through it.

Monster Descriptions

Brownie

Garb: Brown tunic or tabard with two green scout sashes. Suggested: Pointed ears, exaggerated smile. Very short people, as brownies are 18 inches tall.

Summoned: Druid 6 (*Reincarnate*)

Player lives per life: 2

Type: Mystical Fey Humanoid

Q/M Ratio: 1/1

Armor: 1 point natural armor with up to 3 additional points of normal armor.

Weapons: May use a single dagger or short sword.

Immunities: Control. (save for Bardic Charm)

Natural Lives: 3

Abilities & Traits:

Magic-like Abilities: *Flight* (1/life), *Lost* (1/life), *Teleport* (1/life)

Innate Abilities:

Camouflage (1/life)

Blend (Unlimited)

Levels

- 1st No additional abilities
- 2nd **Camouflage** becomes 2/life
- 3rd *Lost* becomes (2/life)
- 4th *Flight* becomes (2/life)
- 5th *Lost* becomes (3/life)
- 6th *Flight* becomes (unlimited)

Description: A small (18 inch tall) being that is a distant relative of elves and leprechauns. They are usually very shy and leery of strangers, but can be helpful if treated well. They have pointed ears, and long pointed noses. Being creatures of the woods, typically wear clothing of brown, green, and other earthy tones.

Centaur

Garb: Furred legging and yellow or white shoes or shoe covers. Green scout Baldric. Suggested: a horse tail, and anything that would make your lower half look more like a horse.

Summoned by: Druid 6 (*Reincarnate*)

Player lives per life: 2

Type: Fey Humanoid

Q/M Ratio: 2/1

Armor: Up to 4 points of normal armor, any shield can be used.

Weapons: Melee weapons and bows (no crossbows).

Immunities: Control. (save for Bardic Charm)

Natural Lives: 4

Abilities & Traits:

Many-Legged

Innate Abilities:

Attuned (2/game): As per the scout ability. If summoned, may carry two enchantments in addition to the one used to summon the centaur.

Tracking (1/life): As per scout ability.

Bowyer (1/life): As archer ability.

Stun Arrow (1/unlimited): As the archer ability.

Flame Arrow (1/unlimited): As the archer ability.

Levels

1st No additional abilities

2nd **Accuracy:** Arrows fired from all bows and crossbows deal +1 additional point of damage.

3rd **Innate Magical Ability: Armor-Piercing Arrow** (1/unlimited): As the archer ability.

4th **Innate Magical Ability: Penetration Arrow** (1/unlimited): As the archer ability.

5th **Tracking** becomes (2/life).

Flame and **Stun Arrow** each become (2/unlimited).

6th **Armor-Piercing Arrow** becomes (2/unlimited).

Description: These creatures are half-horse, half humanoid race. Rumored to have been created by a senile old wizard who was unaware of his actions. Centaurs are usually neutral, and are fierce defenders of their homes.

Dryad

Garb: Seductive attire adorned with leaves and twigs. Suggested: Pointed ears, sparkling green makeup.

Summoned by: Druid 6 (*Reincarnate*) Wizard 6 (*Transform*)

Player lives per life: 2

Type: Mystical Fey Humanoid

Q/M Ratio: 1/1

Requirement: Suggested be female to play a Dryad

Armor: None

Weapons: Single Dagger.

Immunities: Control (save for Bardic Charm)

Natural Lives: 3

Abilities & Traits:

Home Tree

Magic-like Abilities: *Commune* (Unlimited), *Heal* (Unlimited), *Yield* (3/life).

Levels

1st No additional abilities

2nd Gain 1 point of natural invulnerable armor

3rd **Magic-like Abilities:** *Heat Weapon* (1/life), *Warp Wood* (1/life)

4th No additional abilities

5th *Heat Weapon* and *Warp Wood* both become (2/life)

6th Natural Invulnerable armor increases to 2 points.

Description: These creatures are beautiful, mischievous wood spirits. Little is known about them, except they command powerful magic, and always demand a high price for their benevolence. This price is often a male who is seldom seen again.

Giant, Hill

Garb: White and Brown tunic. Suggested: Anything that makes you look bigger, a smear of white or brown face paint.

Summoned by: Druid 6 (*Reincarnate*)

Player lives per life: 2

Type: Humanoid

Q/M Ratio: 1/1

Requirement: Must be a 2nd level monster to play a Hill giant. If summoned, the class sacrificed does not have to be 2nd level, but the player must be a 2nd level monster to play a hill giant.

Armor: 2 points natural armor, up to 2 additional points of normal armor.

Weapons: Melee weapons and boulders.

Immunities: None

Natural Lives: 2

Abilities & Traits:

Large

Strong

Description: Standing 10-15 feet tall, these are slow and simple-minded.

Goblin

Garb: Green ears, most often sown to a head band. Suggested: Browns and tans for garb.

Summoned by: Wizard 6 (*Transform*)

Player lives per life: 0.5. Players who are summoned as goblins, sacrifice 1 life to gain 2 lives as goblins. When the first goblin is killed, the player plays the “next” goblin in a 50 count as per sheer numbers. If the enchantment is dispelled from the first “goblin” the player still gets to play the second life. Treat this as though the player was enchanted and created two separate goblins, each with the enchantment on them.

Type: Humanoid

Q/M Ratio: 0.5

Armor: up to 1 point of normal armor.

Weapons: Single melee weapon under 4 ft in length.

Immunities: None

Natural Lives: 8

Abilities & Traits:

Sheer Numbers: Each player playing a goblin actually represents a horde of them.

When a goblin dies, the player must lie down and count to 50, only to rise again as “another goblin takes his place.” When coming alive, the goblin must do so within 50 ft of where he died, and at least 20 ft away from others if possible. When coming alive the goblin must shout loudly “alive!”

Levels

- 1st No additional abilities
- 2nd Natural lives (**sheer numbers**) increase to 10.
- 3rd May use a short bow, or up to a medium shield.
- 4th Natural lives (**sheer numbers**) increase to 12.
- 5th Natural lives (**sheer numbers**) increase to 15.
- 6th May wear up to two points of armor.

Vulnerabilities:

Weak: Limb shots kill goblins.

Description: These are weaker orcs who team up in small hordes. They commonly talk in high pitched voices and are notoriously weak-willed and devious. They are also often cruel, jealous, selfish, petty and suspicious.



Lizardman

Garb: Green tunic, preferably with cloth scales. Suggested: Green face paint, and green cloth covered flail for his tail.

Summoned by: Druid 6 (*Reincarnate*)

Player lives per life: 2

Type: Humanoid

Q/M Ratio: 1/1

Armor: 1 point natural armor, up to a medium shield can be used.

Weapons: Single natural flail. This is his tail and is considered a red weapon. Melee weapons.

Immunities: Poison

Natural Lives: 4

Abilities & Traits:

Levels

1st No additional abilities

2nd **Poison:** May poison his any non-tail weapon used. (1/game)

3rd **Natural armor** increases to 2 points.

4th Can use javelins.

5th Natural armor increases to 3 points.

Poison becomes (1/life).

6th May wear up to 3 points of additional normal armor.

Description: Lizardmen are dangerous, tribal people who are quite primitive and few in number. They can be found in any climate but most often in marshes and swamps. They are savage in mind but crude in technology.

Mummy

Garb: Mostly wrapped in bandages.

Summoned by: Wizard 6 (*Transform*)

Player lives per life: 4

Type: Undead Humanoid

Q/M Ratio: 3/1

Armor: 1 point natural armor.

Weapons: Single Short Sword.

Immunities: Control, Death, Sorcery, Subdual, Poison

Natural Lives: 3

Abilities & Traits:

Bloodless

Innate Ability:

Touch of Death (Unlimited): as per the assassin ability.

Levels

1st No additional abilities

2nd **Strong**

3rd **Natural armor** increases to 2 points.

4th **Natural armor** increases to 3 points.

5th **Magic Like Ability:** *Awe/Fear* (2/life)

6th **Magic Like Ability:** *Heal* (2/life), self only. (This represents rejoining its body parts).

Description: Mummies are undead creatures that are the corpses of humanoids, wrapped in bandages, and filled with preserving fluids. They are usually associated with a curse. If something concerning the mummy has been desecrated, the mummy may come back to life to kill the guilty party. Other times, it is merely a spirit that has inhabited a body to wreak havoc. They are quite mindless, and will destroy anything that gets in their way.

Pegasus

Garb: A pair of white feather wings and white fur leggings.

Summoned by: Wizard 6 (*Transform*)

Player lives per life: 2

Type: Mystical Beast

Q/M Ratio: 1/1

Armor: 1 point of natural armor.

Weapons: 2 natural short hacking or bludgeoning weapons (no stabbing allowed). These represent hooves.

Immunities: Control

Natural Lives: 3

Abilities & Traits:

Many-Legged

Natural Flight

Magic-Like Ability: *Awe* (1/life)

Levels

1st No additional abilities

2nd **Mount:** May carry one rider.

3rd *Awe* becomes (2/life)

4th **Magic-Like Ability:** *Charm* (1/game)

5th *Charm* becomes (1/life)

6th *Awe* becomes (3/life)

Description: Pegasus are one of the most beautiful and well known creatures. These winged horses are extremely intelligent beasts and sought after by every facet of society for many reasons, not all of which would benefit the Pegasus. They generally choose to ignore most other races, though pegasi will go out of their way to annoy harpies.



Siren

Garb: Seductive gray, blue, or green dress. Aquatic looking if possible. Suggested: Blue and green glitter makeup.

Summoned by: Druid 6 (*Reincarnate*)

Player lives per life: 1

Type: Mystical Humanoid.

Q/M Ratio: 1/1

Requirement: Suggested to be female to play a Siren

Armor: None

Weapons: Single Dagger.

Immunities: None

Natural Lives: 3

Abilities & Traits:

Magic-like Abilities: *Circle of Protection* (1/life), *Yield* (2/life)

Vulnerabilities:

Bound: Sirens are bound to within 50 ft of a single object that is chosen each life. Denote the chosen object to a reeve.

This item cannot be one that is moveable (very large rock, tree, body of water, etc).

Levels

1st No additional abilities.

2nd 1 point of armor can be worn.

3rd *Circle of Protection* becomes (2/life).

4th *Yield* becomes (3/life).

5th *Circle of Protection* becomes (3/life).

6th Gain any two bardic Verbal Spells.

Description: These beings are a race resembling human females, but are something very inhuman. They sing most of their lives, luring unsuspecting travelers to their doom. To help them along, they are both incredibly seductive and extremely beautiful. Both assets they use to give them an advantage over a weary victim.

Skeleton

Garb: White skull mask or face makeup and black tunic. Suggested: skeleton-like painted gloves, anything that makes you look more skeletal.

Summoned by: Wizard 6 (*Transform*)

Player lives per life: 1

Type: Undead Humanoid

Q/M Ratio: 2/1

Armor: up to 2 points of normal armor. Any shield can be used.

Weapons: Melee weapons.

Immunities: Control, Death, Poison

Natural Lives: 1

Abilities & Traits:

Bone

Regeneration (from death)

Levels

1st No additional abilities

2nd Normal armor increases to 3 points.

3rd Natural lives increase to 2.

4th Normal armor increases to 4 points.

5th May use javelins.

6th Natural lives increase to 3.

Vulnerabilities:

Weak: Limb shots kill skeletons.

Lightning Bolt and *Call Lightning*: These act as an *Iceball* (frozen for a 100 count) on a skeleton due to fused limbs. They cannot be used to kill a skeleton.

Resurrection: If used on a skeleton (save those summoned by the spell *Transform*), this forces the skeleton to play out that life as a warrior of the same level as the skeleton.

Description: Skeletons are the animated bones of a corpse. They are mindless and follow the directions of their creators without fear or question. They tend to interpret orders in the most literal way.

Troll, Regenerating

Garb: Dirty green or gray tunic with fur/skin loincloth. Suggested: Crude clothing, tusk-like fangs.

Summoned by: Druid 6 (*Reincarnate*)

Player lives per life: 4

Type: Mystical Humanoid

Q/M Ratio: 3/1

Armor: 1 point of natural armor.

Weapons: Two Red natural 2 point short swords, These are the troll's claws. Melee weapons.

Immunities: None

Natural Lives: 2

Abilities & Traits:

Regeneration

Strong

Levels

1st No additional abilities

2nd **Magic-Like Ability:** *Awe/Fear* (1/life)

3rd Natural armor increases to 2 points.

4th Natural lives increase to 3.

5th Natural armor increases to 3 points.

6th **Magic-Like Ability:** *Awe/Fear* becomes (2/life).

Description: A troll is a vicious, disgusting creature whose very *Presence* is one which strikes fear into most. Their hide is a nauseating mixture of moss greens, grays, blacks, and mottled greens. They are relentless when attacking due to their pea-sized brains.



Unicorn

Garb: White hooded cloak and golden horn. White fur leggings. Suggested: as horse-like as possible.

Summoned by: Druid 6 (*Reincarnate*) Wizard 6 (*Transform*)

Player lives per life: 3

Type: Mystical Fey Beast

Q/M Ratio: 2/1

Armor: None.

Weapons: Single natural magical short sword that deal 2 points thrusting and slashing represents the unicorn's horn.

Immunities: Control (save for Bardic Charm)

Natural Lives: 3

Abilities & Traits:

Home Tree

Many-Legged

Magic-like Abilities: *Heal* (unlimited); *Teleport* (unlimited) - requires the unicorn put its hood over its head in addition to the normal incantation.

Levels

1st No additional abilities

2nd **Magic-like Ability:** *Resurrect* (1/life), requires bringing the dead to the unicorn's home tree and having them and the unicorn touch it while casting the spell.

3rd *Resurrect* becomes (2/life)

4th **Magic-like Ability:** *Lost* (1/life)

5th *Resurrect* becomes (3/life)

6th *Lost* becomes (3/life)

Description: These resemble great white horses with a golden horn springing from its head. They are kind-hearted and will help those in need. They often shy away from violence.



Zombie

Garb: Gray Rags and a gory face makeup. Suggested: the more gore the better.

Summoned by: Wizard 6 (*Transform*)

Player lives per life: 3

Type: Undead Humanoid

Q/M Ratio: 2/1

Armor: none initially

Weapons: 2 bludgeoning blunt clubs. These represent the zombie's fists.

Immunities: Control, Death, Poison

Natural Lives: 4

Abilities & Traits:

Rubbery: Immune to bludgeoning weapons.

Regeneration

Innate Abilities:

Slow: Zombies may only walk, and cannot run or jump. Must make constant noises like screaming, saying "brains," or other such unintelligent words.

Levels

1st No additional abilities

2nd Natural lives increase to 4

3rd Natural lives increase to 5.

4th **Strong**

5th One point of natural armor.

6th Natural lives increased to 6.

Description: foul unfortunate creatures doomed to walk the earth as undead. They are always in pain, and only brains sate that pain for a short time. These are the simple ones raised by dark means as animated corpses.

Note: This zombie is a summoned zombie; Quest game zombies and zombie game's zombies have infinite lives, 100 count deaths, 50 count wounds, and when they "kill" a player, the victim becomes a zombie.

Monster Abilities and Traits

Aquatic: May move through water without dropping to their knees.

Armor, Invulnerability: See Invulnerable Armor in the glossary

Armor, Natural: This armor cannot be *Pyrotechnics* or otherwise removed from the monster (except by damage). Can be *Mended*. It otherwise acts in all ways as normal armor. If protection magics that do not protect normal armor (*Protection from Flame* for instance), will protect natural armor. Natural invulnerable armor can be *Mended*. If normal armor can be worn, it is always destroyed BEFORE natural armor in a given location.

Blend:

I: Repeat x10 “Forest hide and protect me.”

To end the effect repeat x2 “Forest release me”

E: You are considered out of the game. You may move anywhere you like, as long as you remain within 50 ft of a tree.

When you wish to return to the game, recite the phrase to end the effect.

L: If you go more than 50 ft from a tree, you can NOT recite the phrase to end the effect until you are again within 50 ft of a tree. Someone within 20 ft can use tracking to “dispel” this ability.

Bloodless: Immune to the piercing/stabbing attacks of weapons.

Bone: Immune to the piercing/stabbing attacks of weapons.

Camouflage: As per the normal (scout) **Camouflage** class ability.

Home Tree: Must pick a tree, and denote it to the reeves. Any death before the home tree is struck by 10 strikes from a blue or red weapon, or hit by a flame magic (destroying the tree, which can not be *Mended*), does not count towards its total number of lives lost. Instead you must go to your home tree and count to 300 before returning to the game.

Large: Does not have to go to knees in water due to their large size. May use melee weapons to attack flying players..

Many-Legged: The first time a many-legged creature’s leg is injured, it forces them to walk instead of dropping to one knee. A second leg shot that would injure the creature acts as normal (creature drops to one knee, and further shots to the same leg have no effect).

Natural Armor: See **Armor, Natural**.

Natural Flight

I: Repeat x5 “I take Flight,” to land repeat x5 “Landing”

E: Creature cannot be attacked by melee weapons while flying unless the attacker is also flying or **Large**. Creatures flying must still drop to their knees if wounded in the leg (simulates *Wounding* the wings). Creature must flap its arms or state “Flying” every 2 seconds to denote this. Magic and magic-like abilities still require the being to stand still to cast and only verbals and innate abilities can be used while flying.

L: To take off and land, the creature must stand still.

Natural Weapons: Cannot be Heated, Warped, or Enchanted. Things that destroy the weapon take the arm as well. Spells that destroy everything they touch (*Lightning Bolt*, *Fireball*, *Sphere of Annihilation*) the strike natural weapons affect the target as though they hit them in the arm. Touch based abilities, such as *Touch of Death*, can be extended through natural weapons (both ways, by the monster, and by those attacking it). If a touch based ability is used by the creature, through its weapon, the creature must denote the effect immediately following the weapon hitting the victim. No more than a one second delay is reasonable.

Regeneration: Lost limbs return in a 50 count. Act as if resurrected in a 100 count after death. Flame, and Flame magics, *Sphere of Annihilation*, or death by a magical weapon negate these effects. (thus being killed by a *Fireball* stops *Regeneration*, a limb lost to a *Flameblade* or blade-sharpened weapon, cannot be regenerated, etc.)

Strong: Melee weapons (including natural weapons) become Red. Melee weapons that are already Red do an extra point of damage to armor for a total of three

Tough: These creatures are innately able to resist most weapons. Strikes from non-magical weapons do not affect them. Characters with Powerful blows can attack Tough monsters with their weapons.

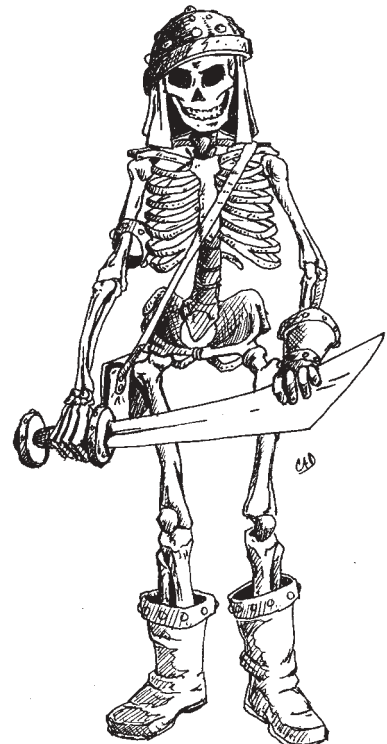



Glossary

Armor: Armor stops blows that would otherwise wound or kill the target. Armor is rated on a scale from one to seven depending upon its ability to stop damage. Some monsters may have more than seven points of armor. Normal armor may be *Mended*.

Armor, Invulnerable: See invulnerable armor.

Abilities, Extraordinary (ex): In many cases, these abilities are activated, act just like magic, and are written in the same way. To be initially activated, these require the player to stand still as per casting magic – unless otherwise noted. If a School is listed, treat that ability as belonging to that magic School for the purpose of immunities. Otherwise, only invulnerability will protect from the ability (though some have immunity to poison and traps, and thus are unaffected by them). These are non-magical in nature. Extraordinary abilities may not be dispelled.

Abilities, Magic (m): These are magical abilities of the class that act in all ways as per the magic listed, save they do not cost magic points, do not require a free hand, and are given a number of uses. These cannot be used in *Anti-Magic* areas. These require the person to stand still – as per casting magic.

Battlegame: A game in which fighting classes (and possibly monsters) are used.

Bounce: A projectile, arrow, or magic ball hitting the ground before it hits its target.

Count: Synonymous with second. A 300 count requires 300 seconds to elapse.

Destroyed: Items that are destroyed may be repaired using the *Mend* spell or appropriate class ability unless otherwise noted under the description of the effect which destroyed the item. A destroyed weapon or shield may be recovered by returning to base and waiting for a 100 count. This simulates retrieving a new one from base. Destroyed items may not be used until they are repaired. Destroyed armor may be repaired by using the *Mend* spell for each point in each location to be recovered.

Dispelled: Being the target of a successfully cast *Dispel Magic*.

Ditch battle: A non-class game with two sides. Armor and projectiles are not used. After each battle, the winning team sends over the first person that died on their side to the losing side, and another round is fought. Repeat.

Draw length: The distance between the center of the string and the furthest point of the arrow shelf at the center of the bow.

Enchantment (E): A magic cast on a target player or their equipment, that persists until used up or removed by death or the appropriate magic. Colored strips tied to the bearer denote these.

Engulfing: Engulfing effects affect the victim even if they hit only garb, worn equipment, or wielded equipment. Other affects only function on items or players they physically touch.

Fixed enchantment (FE): A magic cast on an area of ground that persists until used up, the caster leaves a 100 foot radius around the enchantment, it is removed by the appropriate magic, or the caster dies. These do not prohibit the caster from carrying a normal enchantment.

- a. Fixed enchantments are considered to extend upwards to the sky for game purposes. Even flying creatures are impeded by them.
- b. Fixed enchantments, unless otherwise noted in the magic's description, may never be pre-placed before casting.
- c. Reeves, if requested, may assist in the placing of a magic-user's markers for a fixed enchantment.

Game Item: Some games have certain items or players designated as necessary for the game to function. Such important ‘game items’ (flags, relics in a relic quest, team captain in a ‘kill the captain’ battlegame, etc.) may never be removed from play in any way, including being *Entangled*, *Teleported*, placed in a *Circle of Protection*, etc. These items never bestow their immunities to their bearers. For example, a Warrior carrying a game item flag has the flag hit by an *Iceball*. The warrior is frozen, but the other team may take the flag out of his frozen hands and recover it. In the case of a *Teleport*, the item is left behind.

Hit Location: A player's body is divided into 5 legal hit locations: left arm, right arm, left leg, right leg, and torso.

Immunities: If a creature or player has immunities, these take precedence over losing points of invulnerable armor or normal invulnerability. Immunities never extend to any sort of non-invulnerable armor or equipment.

Inch Pounds: The poundage measured at maximum draw multiplied by the distance between the center of the un-drawn string and the center of the string in the locked position.

Instant Kill Effects: Effects – such as some siege weapons – that kill you instantly, regardless of where they hit you. Hits to the head, neck, and feet on ground still don't count, however.

Invulnerability: A form of protection from battlefield effects, consisting of the following properties:

- One point of invulnerability will negate one hit to a person. A hit is defined as something that could damage or hinder the target, such as: *Entangle*, *Fireball*, a melee weapon strike, Siege Weapon strike, etc. Effects that are not stopped by invulnerability include *Teleport*, *Honor Duel*, and any strictly beneficial magic such as *Heal* or *Cure Poison*.
- Invulnerability is considered to be skin tight and does not extend to equipment worn or carried. i.e. it will not prevent weapons nor armor from being affected by magic or damage; however, it will prevent an effect from carrying through to a player from his equipment. Invulnerability is not sectionalized like armor.
- Invulnerability is only used up when it stops something that would actually affect the bearer. An Anti-Paladin who is immune to fire and wearing invulnerability, will not lose a point of invulnerability when struck by a *Fireball*.
- Invulnerability may not be *Mended*.

Invulnerable Armor: Not to be confused with invulnerability, this is a magical armor particular to some monsters and not normally usable by the standard classes.

- Functions just like invulnerability, except that it is sectional like normal armor. Thus 2 points of invulnerable armor grants 2 points of protection to each hit location.
- Magic casters must specify which area (torso, right/left arm/leg) of invulnerability that they destroyed with Verbal magic. If the caster fails to specify, or in the cases of spells of mass destruction like *Doomsday*, it is at the location of the target's choice.
- Invulnerable armor can be *Mended*.

Item: A single object is considered to be any item whose parts are not easily usable independently. (A sword, a shield, a throwing weapon, etc.). This requires a substantial connection to be made between all parts of an object i.e. a cord connecting a breastplate to a greave does not constitute a single object but a full suit of plate would. This applies to magic that refers to targeting a single object and does not override any other rules governing how a specific magic or type of magic interacts with other specific objects. I.e. *Mend* only repairing a single point of armor in a single hit location.

Line of Sight: Verbal magic and abilities require that the target be visible to the caster upon completion of the incantation. If the target of the verbal magic or ability is wholly hidden outside of the casters view, such as short sword completely hidden behind a shield, then the magic or ability will be expended without affecting the target. If the caster can see a portion of the target, no matter how small, upon completion of the incantation, the spell will affect the target as normal. Thornwall and Wall of Force block line of sight.

Magic: A spell, magical ball, neutral, magical class ability, enchantment, or fixed enchantment.

Magical Ball (B): A type of magic that involves charging a ball that is then thrown at a target. Magical balls are reusable. The number of times a magical ball is bought determines the maximum number of balls that may be charged or in effect at once. All magical balls charged at the same time must be thrown at the same time. You must repeat the incantation once for each ball to be charged; i.e. to charge four *Fireballs* you would have to repeat “Fireball” twenty times. Magical balls, once cast, remain charged for two minutes, after which they must be recast. Magical balls cast with the left hand may be transferred to the right hand for throwing. When thrown, all hits by a magical ball count except head or throat shots. This includes foot shots, tail hits and grazes. A hit to a hand holding a weapon affects it as if the ball hit the weapon – which in some cases affects the holder (e.g., *Iceball*). A magic-user may carry a maximum of 12 magical balls, regardless of how many were purchased.

Magic-user: Bard, Druid, Healer, Wizards, and any monster that can cast a spell or use a spell-like ability. Magic-users buy magic from the appropriate spell list under the Magic section.

Mundane: Term used to describe some who does not play Amtgard or something that is “outside” the scope of the game (the real world). When shouted during a game, “Mundane” announces the presence of someone who should be allowed to pass through the game unhindered.

Natural armor: This is normal armor in every way except that it may not itself be the target of spells or effects – with the exception of *Heal*, which will repair a single point of natural armor in a single location.

No-Magic Game: A battlegame that uses classes, but no spell casting.

Non-class Game: This is a game where the classes are not used. Many of the battlegames listed can be played in this fashion, and a number of games, most notably ditch battles, always forgo the use of classes.

Neutral (N): A magic that alters the nature of that on which it is cast. Neutrals can never be dispelled, and a person may have more than one of these operating at the same time.

Object: See Item.

Out of Game: This term refers to players or objects that cannot affect nor be affected, by anything and are unnoticeable for game purposes.

Quest: A special battlegame designed with special rules. Monsters are often used in these.

School: All magic falls under one of eight schools of magic. Please note that immunities are based on what School a magic is in. Therefore, as *Hold Person* is a spell of the Subdual school, a Barbarian, immune to subdual effects, is not affected. *Stun*, on the other hand, is of the Sorcery school, thus Barbarians would be affected by it.

Simul-cast: This refers to the ability of some magic to be cast more than once at the same time. Simul-cast enchantments cannot be worn with more than one layer of other simul-cast enchantments, even with the *Stack* magic or similar class abilities. When simul-casting magic you must repeat the incantation once for every layer of the enchantment to be cast or magical ball to be charged. You may not add more layers to simul-cast magic after the initial casting.

Spell: a magic that has a direct and immediate effect.

Spellball: See Magical ball

Verbal magic: These ranged spells utilize spoken components and need not touch or hit their target. Verbal magic can only be cast on targets the caster can see. There is no way – other than being immune, out of range, or not being seen – to avoid Verbal magic. A weapon can usually be hidden behind one’s back to prevent magic such as *Heat Weapon* from being able to target it.



Credits

The Rulebook Committee

Amren
Aramithiris
Blackhawk
Bolt
Brennon
Franchesca
Garik
Lukor
Phocion
Raphael
Roger

Prior Committee Members

Astrean Andalsa
Bag'em
Belgarion Torrid
Euric
Father Thomas
Kayrana Lissa
Kitirat O'Turea
Ian of Shadowvale
Ivar Nefarius
Q
Rigel Orionis
Talon Starchaser
Terarin
Theo Blackflame
Topknot
Rath
Savaen
Scarhart
Shendo
Spirit
Sylvanas
Talisán
Tonbo
Tristan

Rulebook Contributors

Alucard
Akrith
Andacar
Anthony
Asmund
Blackrose
Blackthorne
Crosser
Drake
Exedor
Finn
Glen(alth)
Gwynne
Jabberwock
Jaeden
Juju
Lakus
Lucas
Luke Wyngarde
Lyvyndyr
Okami Kurai
Oznog
Qalor Tolandia
Quinn
Randall
Ralph

Art Contributors

Andy 2, 24
Theresa Brandon 17, 65
Cat cover, content, 1, 11, 12, 22, 25, 27, 29, 41, 59, 61
Diego 3, 4, 16, 19, 23, 30, 57, 60, 62, 63
Gwynne 9
Juan Muro 18, 21, 31
Rob 36
Rogan 17, 20, 43, 54
Terarin 7, 14, 15, 40, 53
Torg 48
Xger 15, 20, 26, 28